

The Series 200 make up an integrated system of hinges developed to provide a solution to any situation involving concealed hinges.

Bright nickel plated steel cup and arm.

Dimensions of the Ø 35 mm cup.

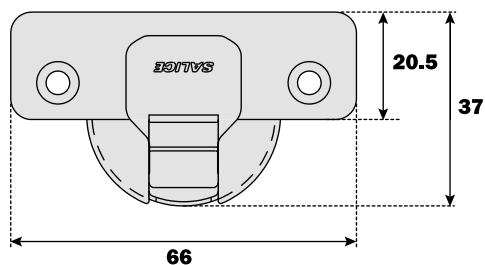

Constant "L" value of 0.7 mm (it does not change during side adjustment).

Approx. number of hinges required according to the door dimension and weight.

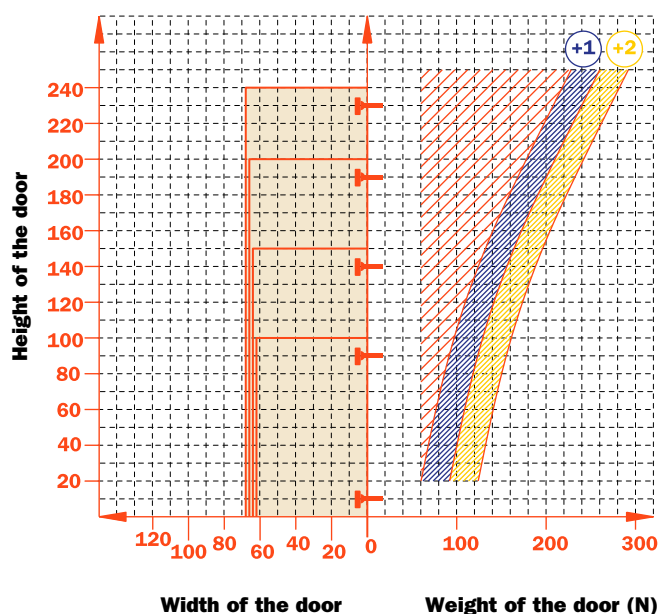

Adjustments





Compensating side adjustment from -1.5 mm to +4.5 mm.
 Height adjustment ± 2 mm.
 Depth adjustment with Series 200 mounting plates +2.8 mm.
 Depth adjustment with Domi snap-on mounting plates from -0.5 mm to +2.8 mm.
 Anti-sliding safety stop.

Mounting plates

Symmetrical and asymmetrical bright nickel plated steel or die-cast Series 200 mounting plates.
 Snap-on assembly on Domi mounting plates.
 Positioning with pre-determined stop on traditional Series 200 mounting plates.

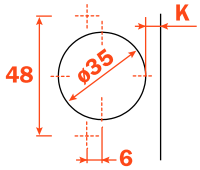
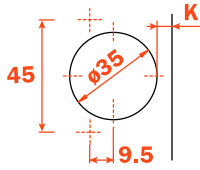
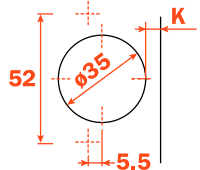
N.B. : Use POZIDRIVE No. 2 screwdrivers for all screws.

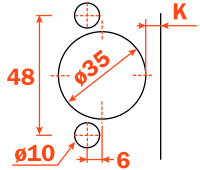
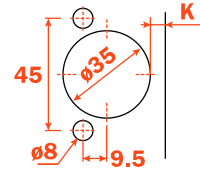
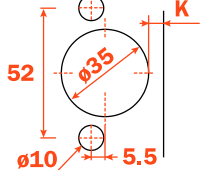
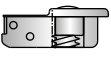
Drillings and fixings

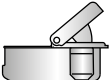
| | | | | | | | | | | | | | |
|-------------------|---|---|--|---|---|---|---|---|---|---|---|---|---|
| | |  |  |  | | | | | | | | | |
| Wood screw |  | A | A | A | A | P | P | P | P | U | U | U | U |
| | |  |  |  | | | | | | | | | |
| Rapido |  | 6 | 6 | 6 | 6 | 7 | 7 | 7 | 7 | 2 | 2 | 2 | 2 |
| Dowel |  | B | B | B | B | R | R | R | R | W | W | W | W |
| Logica |  | I | I | I | I | J | J | J | J | Q | Q | Q | Q |

Use this table to identify the available drillings and fixings.

Fill the third position of the hinge code number with the letter or the number corresponding to your choice. I.e.: C2_BA99.

↑
Fill this position with the chosen letter or number.



Technical information

For thicker doors max. 28 mm.
Hinge with greater opening angle and reduced operating profile.
 8.5 mm deep die-cast cup.
 155° opening.
 Possible drilling distance on the door (K): from 3 to 9 mm.
 Compatible with all traditional Series 200 mounting plates and with all Domi snap-on mounting plates.

Space needed to open the door

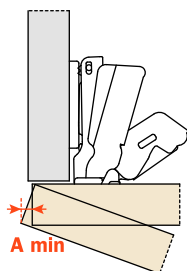

| | T= | 16 | 18 | 20 | 22 | 24 | 25 | 26 | 27 | 28 |
|-----|-----------|-----|-----|-----|-----|------|------|------|----------------------------|----------------------------|
| K=3 | A= | 0.0 | 0.0 | 0.0 | 0.0 | 0.0 | 0.10 | 0.40 | 0.75 | 1.20 |
| K=4 | A= | 0.0 | 0.0 | 0.0 | 0.0 | 0.0 | 0.15 | 0.45 | 0.85 | 1.35 |
| K=5 | A= | 0.0 | 0.0 | 0.0 | 0.0 | 0.0 | 0.20 | 0.50 | 0.95 | 120° 1.70 |
| K=6 | A= | 0.0 | 0.0 | 0.0 | 0.0 | 0.0 | 0.25 | 0.60 | 1.10 | 120° 1.95 |
| K=7 | A= | 0.0 | 0.0 | 0.0 | 0.0 | 0.0 | 0.30 | 0.70 | 1.30 | 100° 2.30 |
| K=8 | A= | 0.0 | 0.0 | 0.0 | 0.0 | 0.0 | 0.35 | 0.85 | 120° 1.70 | 100° 2.80 |
| K=9 | A= | 0.0 | 0.0 | 0.0 | 0.0 | 0.15 | 0.55 | 1.20 | 100° 2.15 | |

With stop device at 100° item **S2BM37XG**
 With stop device at 120° item **S2AM37XG**

The above values are calculated on the assumption that the doors have square edges. They are reduced if the doors have radiussed edges.

Spaces with removable components.

“C” value

The door combined with a mounting plate H=0 and a straight arm hinge opens at 90° with lateral door protrusion of 6 mm.

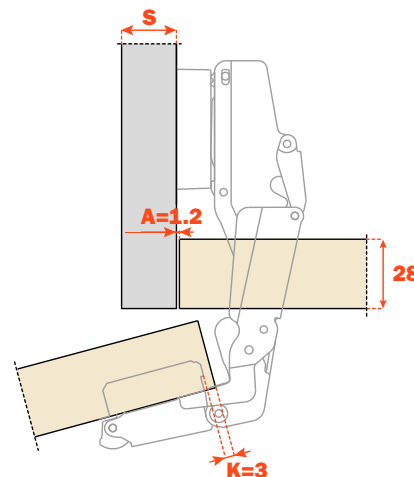
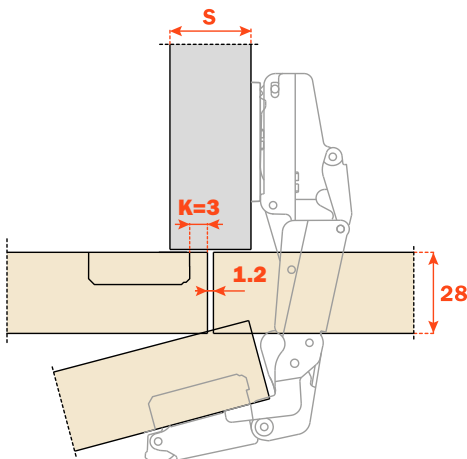
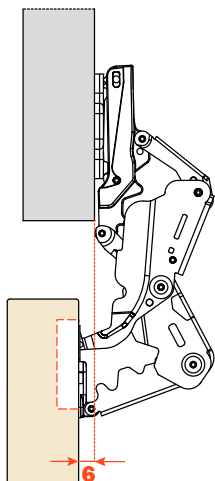

Packing

Boxes 100 pcs.
Pallets 2.400 pcs.

CA sprung hinge

Use these formulas to determine the type of hinge arm, the drilling distance "K" and the height of the mounting plate "H" which is necessary to solve each application problem.

To limit the opening of the hinge, see the leaflet "Accessories".

Use the tables "Drillings and fixings" at page 3 to complete the code number of the desired hinge.

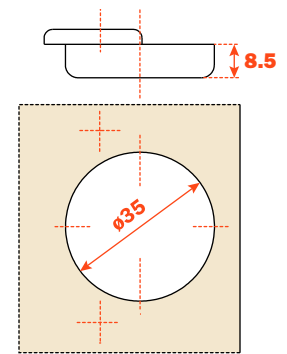
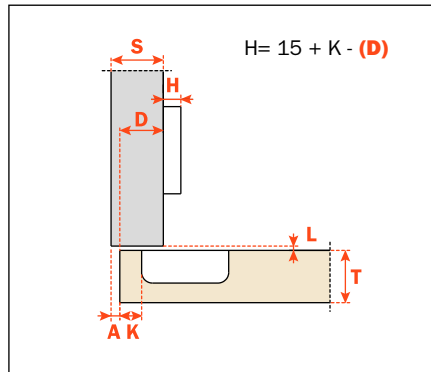
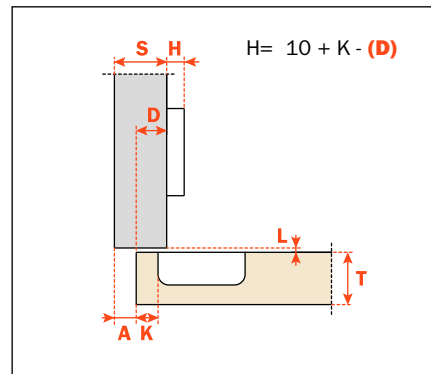
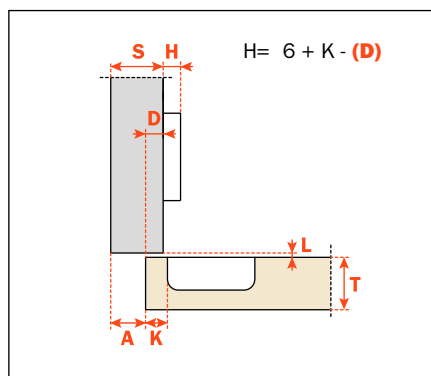
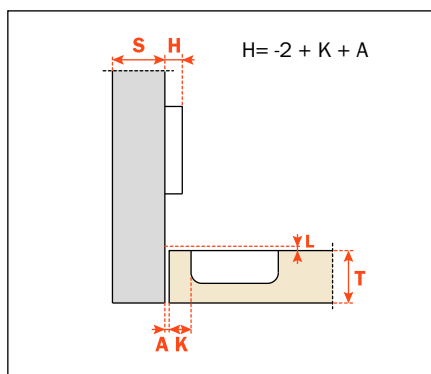
**Arm 0****CA - C2_KA99****Arm 5****CA - C2_KD99****Arm 9****CA - C2_KG99****CA - C2_KP99**