



Smove
SALICE



Smove is a device used to soften the closing action of any furniture door with concealed hinges. The universal adapter, made of durable plastic, enables Smove to be used with all brands of hinges. This compatibility is ensured by the extra-wide bridge of the adapter.

D088X_G - Smoveholder



Smove can be used with doors of any dimension. Just one damper is sufficient for doors with up to 3 hinges; it is possible to use more dampers on the same door to increase the decelerating effect.

D088XSG - 14 mm



Screw-fix adapter for doors with "R" recess between 0 and 12 mm (full overlay). Smove works properly when it bears against the flange of the hinge. For this reason the appropriate adapter must be selected.

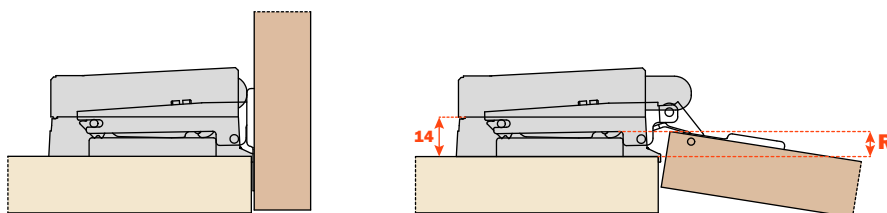

D088XLG - 20 mm



Screw-fix adapter for doors with "R" recess between 10 and 16 mm (half overlay). Smove works properly when it bears against the flange of the hinge. For this reason the appropriate adapter must be selected.

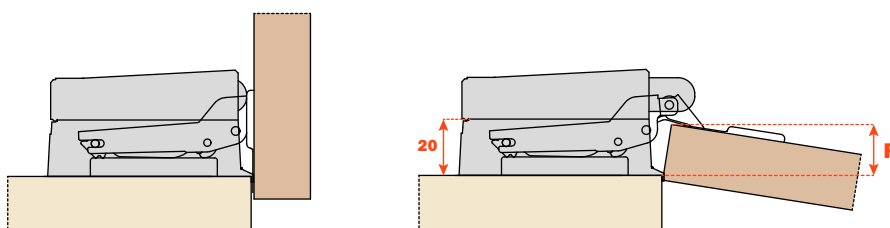

Assembly instructions

Place the adapter over one "wing" of the mounting plate. Use the front stop for the correct depth positioning.

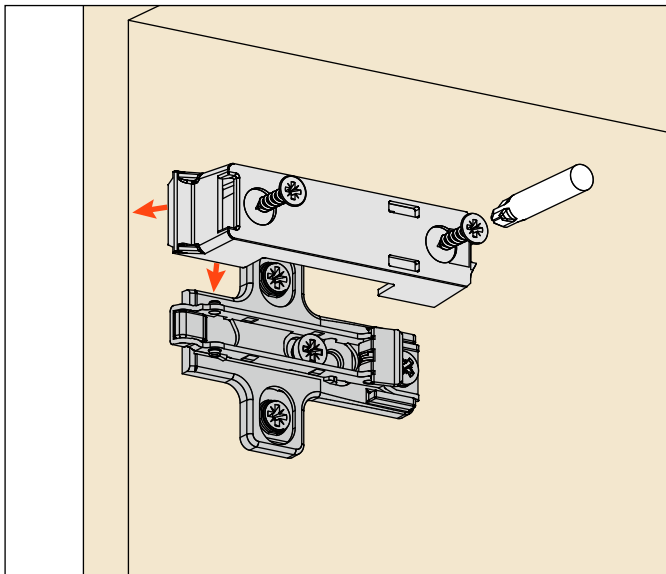

Fix the adapter in position using woodscrews.

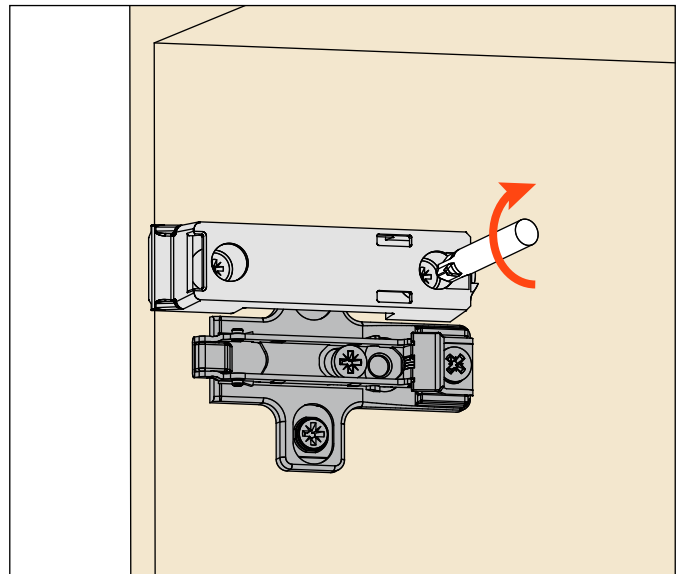

Insert the Smove piston assembly, sliding it in the direction indicated by the arrow.

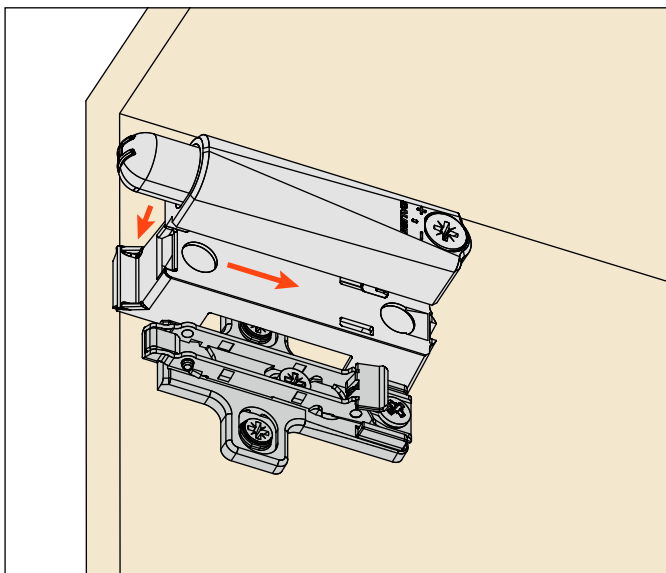

It is possible to reduce or increase the decelerating effect by turning the screw indicated.

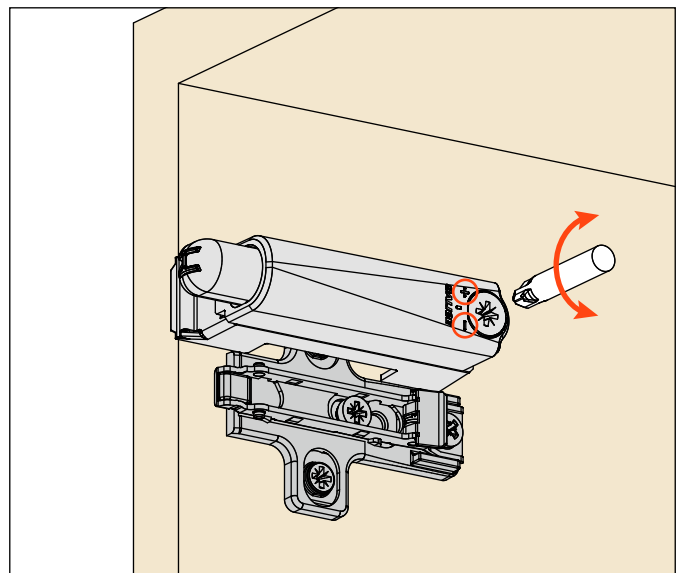

To remove the Smove piston assembly, insert a screwdriver in the indicated slot and prise it off.

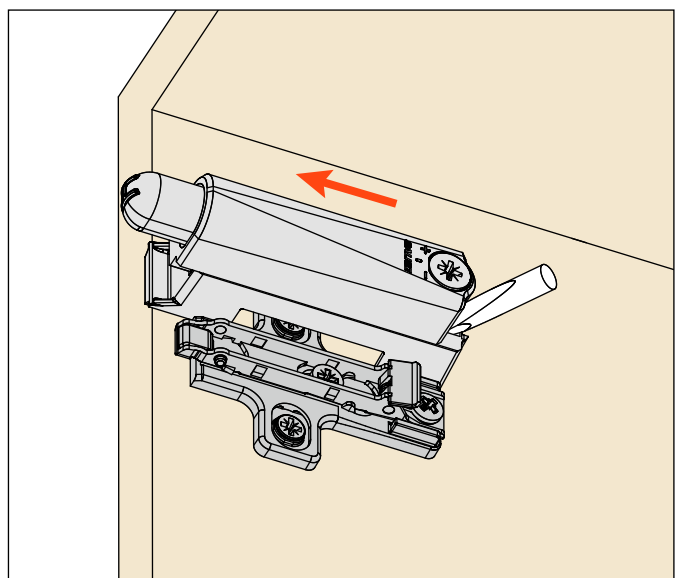
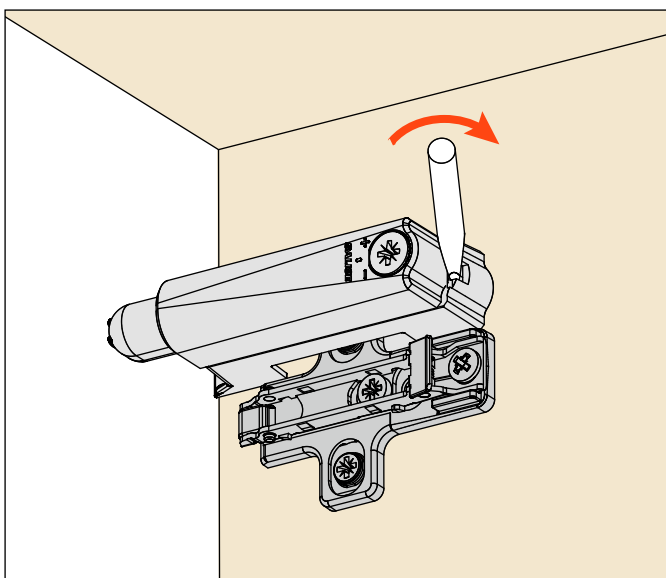

ARTURO SALICE S.p.A.

VIA PROVINCIALE NOVEDRATESE, 10
22060 NOVEDRATE (COMO) ITALIA
TEL. 031 790424
FAX 031 791508
info.salice@salice.com
www.salice.com

DEUTSCHE SALICE GMBH

RUDOLF DIESEL STR. 10
POSTFACH 1154
74382 NECKARWESTHEIM
TEL. 07233 9807-0
FAX. 07233 9807-16
info.salice@deutschesalice.de
www.deutschesalice.de

DEUTSCHE SALICE GMBH

VERKAUFSBÜRO NORD
RINGSTRASSE 36/A30 CENTER
32584 LÖHNE
TEL. 05731 15608-0
FAX. 05731 15608-10
vknord@deutschesalice.de
www.deutschesalice.de

SALICE FRANCE S.A.R.L.

ROUTE DE GOA ZAC LES 3 MOULINS
06600 ANTIBES
TEL. 0493 330069
FAX. 0493 330141
info.salice@salicefrance.com
www.salicefrance.com

SALICE ESPAÑA, S.L.U.

CALLE COPÉRNICO, 11
POLÍGONO INDUSTRIAL
COLL DE LA MANYA
08403 GRANOLLERS (BARCELONA)
TEL. 938 45 88 61
FAX 938 49 11 97
info.salice@saliceespana.es
www.saliceespana.es

SALICE UK LTD.

KINGFISHER WAY
HUNCHINGBROOKE BUSINESS PARK
HUNTINGDON CAMBS PE 29 6FN
TEL. 01480 413831
FAX. 01480 451489
info.salice@saliceuk.co.uk
www.saliceuk.co.uk

SALICE AMERICA INC.

2123 CROWN CENTRE DRIVE
CHARLOTTE NC. 28227
TEL. 704 8417810
FAX. 704 8417808
info.salice@saliceamerica.com
www.saliceamerica.com

SALICE CANADA INC.

4025 SLADEVIEW CRESCENT
UNIT # 7-9
MISSISSAUGA, ONTARIO L5L 5Y1
TEL. 905 8208787
FAX. 905 8207226
info.salice@salicecanada.com
www.salicecanada.com

SALICE CHINA

(SHANGHAI) CO. LTD.

1st FLOOR, B1 BLDG 928 MINGZHU ROAD
XUJING, QINGPU DISTRICT
SHANGHAI 201702 - CHINA
Tel. 021 3988 9880
Fax 021 3988 9882
info.salice@salicechina.com
www.salicechina.com