

# FR 7100 SCC



<b>SLIDE TYPE:</b>	Full-Extension Drawer Slide - Progressive-Action
<b>MOUNTING:</b>	Bottom Mount

<b>WIDTH:</b>	24 mm
<b>LOAD CAPACITY:</b>	dynamic up to <b>120 kg</b> (full-ext.) dynamic up to <b>105 kg</b> (over-ext.)



**MATERIAL:** stainless steel 1.4509 (SCC)

**FEATURES:** solid delrin\* rollers

**SPECIFICATIONS & NOTES:**

- ▶ cabinet profile with holes and drawer profile without holes for welding
  - ▶ high lateral stability through specially formed middle profile and guide rollers
  - ▶ ideal running characteristic and smoothness of running through integrated progressive-action
  - ▶ safety clip mounted in middle profile
  - ▶ double-sided captive profile
  - ▶ self closing, soft stop
- 
- Ⓢ also available with 60 mm over-extension
  - Ⓢ on request, also available as heat resistant model (up to 110° C) – load capacity 90 kg (full-ext.), 80 kg (over-ext.)

\*DuPont (TM) Delrin®

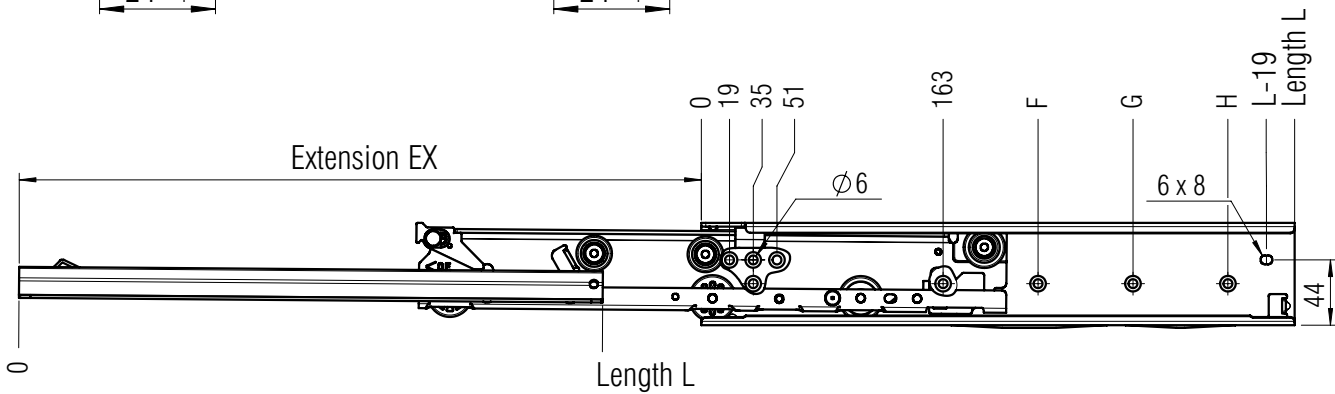
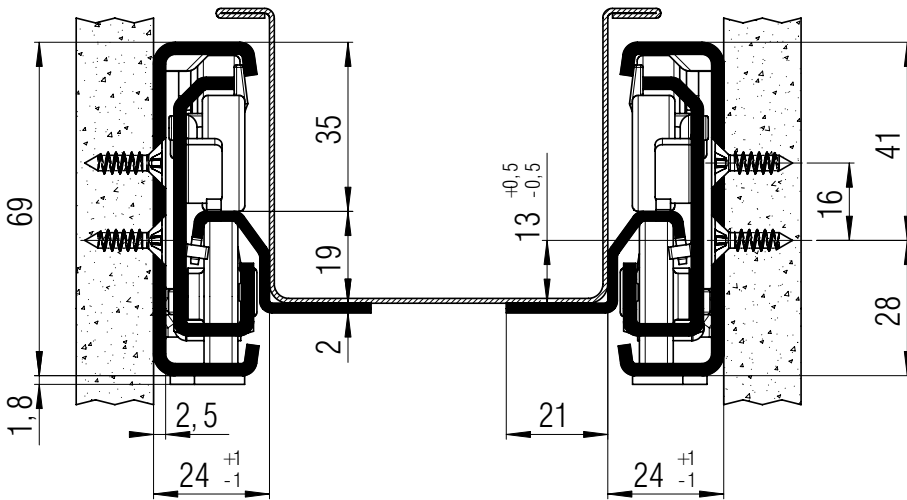

screw holes for 4,5 mm spax screws

L mm	EX full-ext.	EX over-ext.	F mm	G mm	H mm	Weight per pair (kg)	Order No. full-ext.	Order No. over-ext.
400	385	460	323			3,64	▶ 7130	*
450	435	510	355			4,11	▶ 7131	*
500	485	560	291	451		4,57	▶ 7132	*
550	535	610	323	483		5,04	▶ 7133	*
600	585	660	355	547		5,50	▶ 7134	*
650	635	710	355	611		5,97	▶ 7135	*
700	685	760	355	515	643	6,43	▶ 7136	*
750	735	810	355	547	675	6,90	▶ 7137	*

Packing Unit: 400-600 mm: 4 sets per box; 650-750 mm: 2 sets per box ▶ prompt delivery \* minimum order quantity and lead time on request!

