

FR 790 SCC-SC

SLIDE TYPE:	Full-Extension Drawer Slide - Progressive-Action
MOUNTING:	Side Mount

WIDTH:	18 mm
LOAD CAPACITY:	dynamic up to 68 kg (full-ext.) dynamic up to 53 kg (over-ext.)



MATERIAL:	stainless steel 1.4509 (SCC)
------------------	------------------------------

FEATURES:	solid delrin* rollers
------------------	-----------------------

SPECIFICATIONS & NOTES:

- ▶ cabinet profile with bayonet mounting tabs
 - ▶ drawer profile without screw holes
 - ▶ high lateral stability through specially formed middle profile (material thickness 2 mm) and guide rollers
 - ▶ ideal running characteristic and smoothness of running through integrated progressive-action
 - ▶ safety clip mounted in middle profile
 - ▶ double-sided captive profile
 - ▶ self closing, soft stop
-
- ① compatible with regular-extension drawer slide SCC-SC
 - ① tool-less quick assembly of the cabinet profile
 - ① standard grid rail (see drawing)
-
- ① on request, also available as heat resistant model (up to 110° C) – load capacity 50 kg (full-ext.), 40 kg (over-ext.)

*DuPont (TM) Delrin®

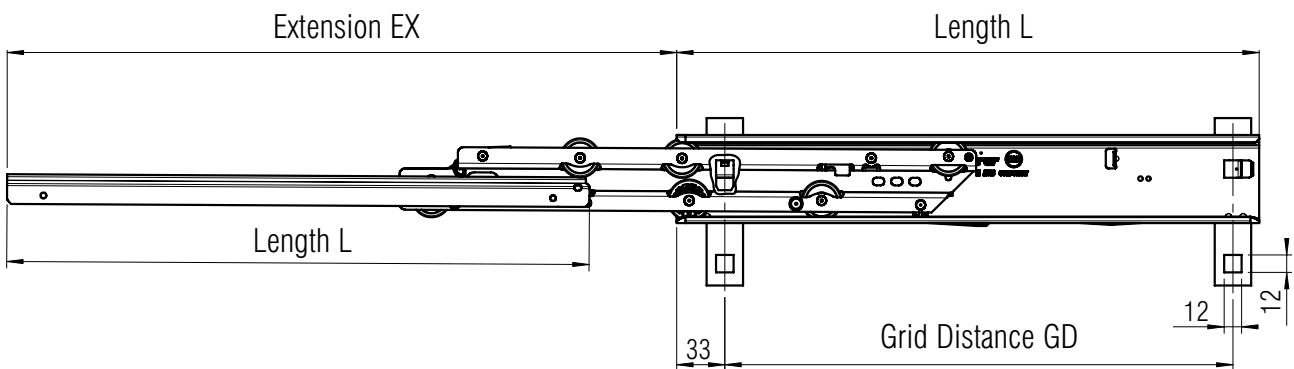
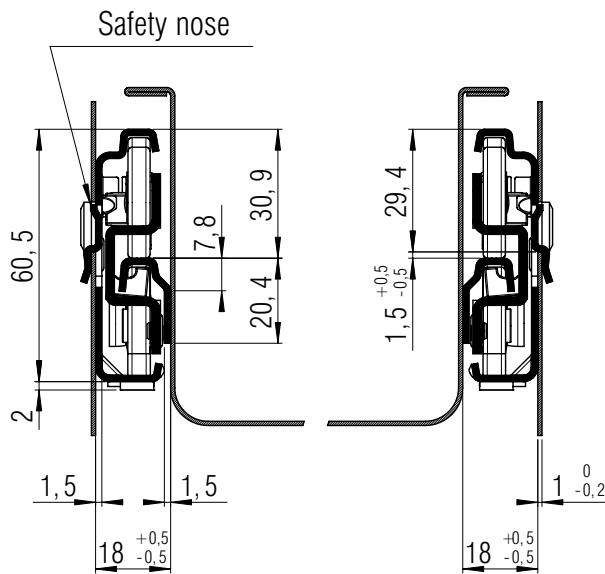

L mm	EX full-ext.	EX over-ext.	GD mm	Weight per pair (kg)	Order No. full-ext.	Order No. over-ext.
350	335	410	299	1,62	*	*
400	385	460	349	1,68	*	▶ 8021
450	435	510	399	2,10	*	*
500	485	560	449	2,34	*	▶ 8023
550	535	610	499	2,58	*	▶ 8024
600	585	660	549	2,82	*	▶ 8025
650	635	710	599	3,06	*	▶ 8026
700	685	760	649	3,30	*	▶ 8027
750	735	810	699	3,54	*	*

Packing Unit: 5 sets per box

▶ prompt delivery * on request