



Push
SALICE



Push

*Push to open system
for handle-less doors*

Mechanical Push

Retaining catches for wooden doors
Retaining catches for aluminium-frame doors
Adapters
Spacers and insertion tool for retaining catch
Assembly instructions and drillings

page 6
page 10
page 11
page 12
page 13
page 14

Magnetic Push

Adapters
Assembly instructions
Retaining catch application

page 20
page 21
page 22
page 25



Series 200

Technical features
94° opening for thicker doors
110° opening
155° opening
155° opening for thicker doors
Complementary hinges:
for wooden doors with positive angled assembly
crampon hinges

page 28
page 30
page 32
page 34
page 36
page 38
page 40



For metal profiles

Practical System
Series 200

page 44
page 47



Serie B

*Hinges that need to be
bonded to glass*

For glass doors

Technical features
110° opening

page 52
page 53

Serie B

*Hinges for half-inset doors
or doors with moulded profiles*

For wooden doors

Technical features
110° opening

page 54
page 56



Accessories

Screw cover caps
Flange cover caps
Spacers for Series 200 hinges
Stop devices

page 60
page 60
page 60
page 61

Mechanical Push



Mechanical Push

The PUSH-System is a self-opening system for the doors of all types of handleless furniture.

It consists of a series of self-opening hinges, release devices that can be fitted to the top, base or side panel of the cabinet, and retaining catches to be fitted to the back of the door.

The retaining catches can be pressure-fixed or screw-fixed.

For doors over 1600 mm in height, we suggest that you use two mechanical release catches.



DP1SNB - beige



DP1SNG - grey

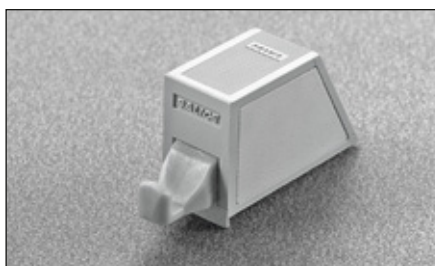

With assembly stop device

Packing
Boxes 300 pcs.

Installation of mechanical Push with adhesive strip

For correct application and to ensure optimal endurance, please follow the following procedure:

- 1)** clean and degrease the cabinet surface where the release device is to be installed using an acetone based cleaner;
- 2)** remove the protective strip from the adhesive;
- 3)** place the release device in position and apply a firm pressure for about one minute;
- 4)** allow a period of 12 hours to elapse before subjecting the PUSH-System to continuous usage.



Mechanical Push - Release device to be screw-fixed

DP3SNB - beige



DP3SNG - grey

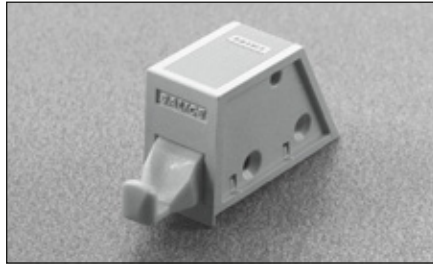

With assembly stop device

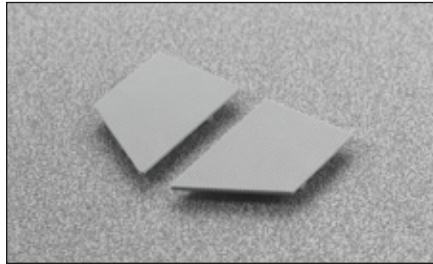
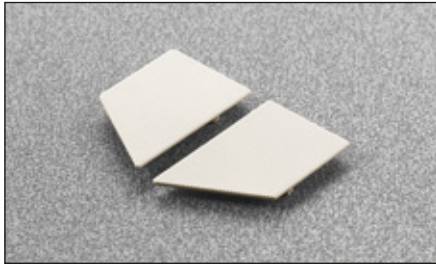

Packing
Boxes 300 pcs.

DP3SNBR - beige



DP3SNGR - grey



Without assembly stop device

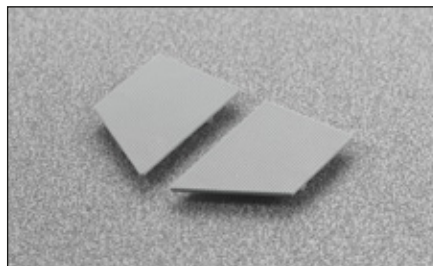
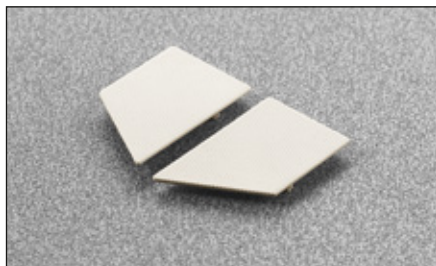

Packing
Boxes 300 pcs.

DP4SNB - beige

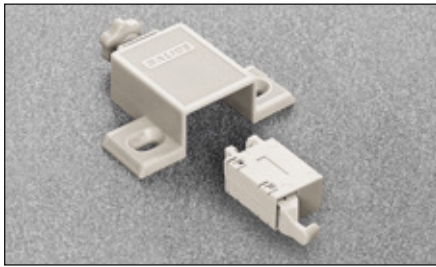

DP4SNG - grey

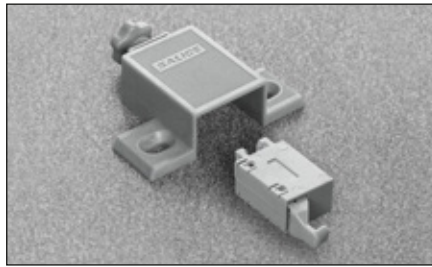

Single adapter with depth and sideways adjustment and release device. Without assembly stop device.

Packing

Boxes 300 pcs.

DP5SNB - beige

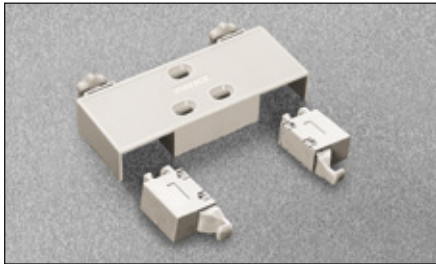

DP5SNG - grey

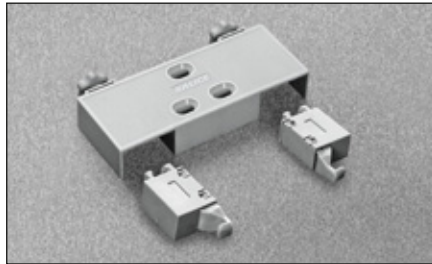

Double adapter with depth and sideways adjustment and release devices. Without assembly stop device.

Packing

Boxes 150 pcs.

N.B.: Drilling patterns at page 14

Technical information on the adjustable mechanical Push

The adjustable Push consists of a release device and a screw-fixed adapter which have been developed to improve the locating action of the system.

The adjustable Push now has a depth adjustment facility with a range of -1 mm to + 2.5 mm which is controlled by a small adjuster wheel located at the back of the adapter.

In addition, the adapter has a sideways adjustment facility of ± 2 mm. This is achieved by loosening the two fixing screws and adjusting the position of the adapter using the elongated holes. Finally, the screws must be retightened.



Mechanical Push - Retaining catches for wooden doors

DP29SNB - beige



DP29SNG - grey



Retaining catch for wooden door.
Knock-in.

Packing
Boxes 300 pcs.

DP29SNBMC - beige



DP29SNGMC - grey



Retaining catch for wooden door and special
assemblies.
Knock-in.

Packing
Boxes 300 pcs.

DP29SNBI - beige

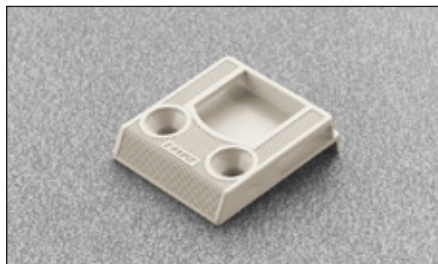

DP29SNGI - grey

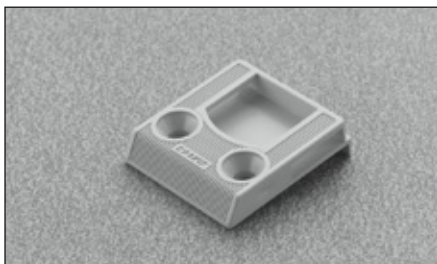

Retaining catch for wooden door.
With assembly stop device.
Screw-on.

Packing
Boxes 300 pcs.

DP29SNBR - beige



DP29SNGR - grey

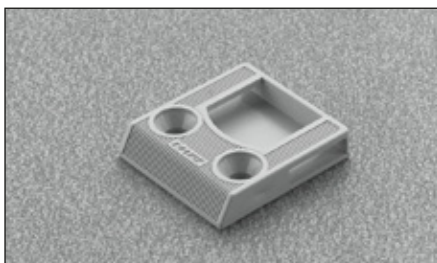

Retaining catch for wooden door.
Without assembly stop device.
Screw-on.

Packing
Boxes 300 pcs.

N.B.: Drilling patterns at page 15

DP29SNBA - beige



DP29SNGA - grey



Retaining catch for aluminium-frame door
width = 35 - 45 mm.

Packing
Boxes 300 pcs.

DP29SNBB - beige



DP29SNGB grey



Retaining catch for aluminium-frame door
width = 17 - 35 mm.

Packing
Boxes 300 pcs.

DP29SNBP - beige



DP29SNGP - grey



Retaining catch for aluminium-frame door
Practical.

Packing
Boxes 300 pcs.

N.B.: Drilling patterns at pages 16 and 17

DP52SNB - beige

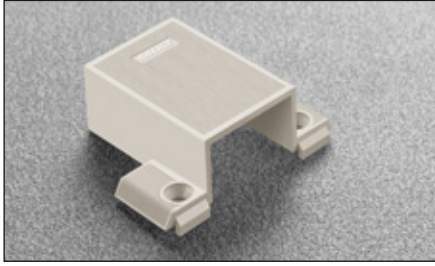

DP52SNG - grey

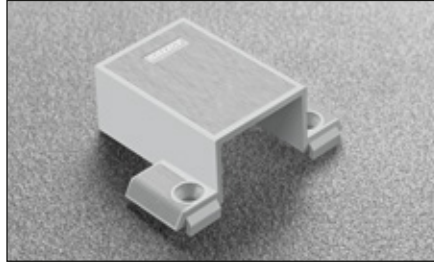

Single adapter.
6x40 mm drilling.
With assembly stop device.
DP53SN = single adapter with sideways adjustment.

Packing
Boxes 300 pcs.

DP52SNBR - beige

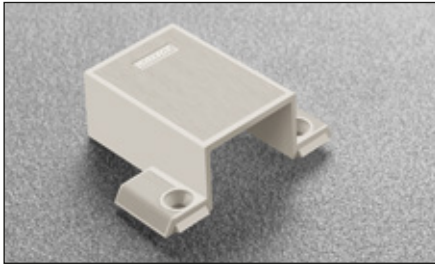

DP52SNGR - grey

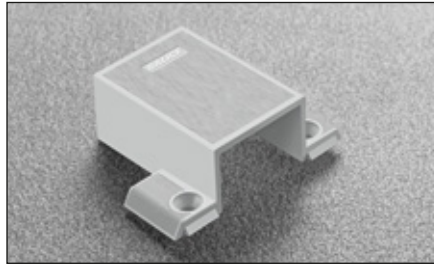

Single adapter.
6x40 mm drilling.
Without assembly stop device.
DP53SN_R = single adapter with sideways adjustment.

Packing
Boxes 300 pcs.

DP54SNB - beige



DP54SNG - grey

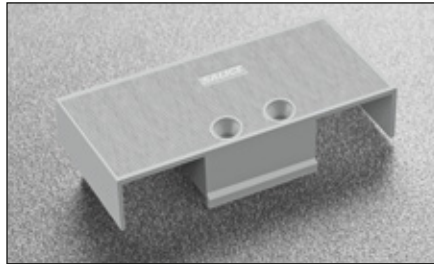

Double adapter.
6x16 mm drilling.
With assembly stop device.

Packing
Boxes 150 pcs.

DP54SNBR - beige



DP54SNGR - grey

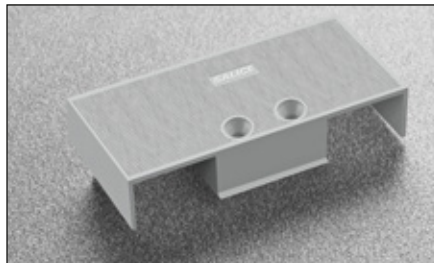

Double adapter.
6x16 mm drilling.
Without assembly stop device.

Packing
Boxes 150 pcs.



DP44XXBD - beige

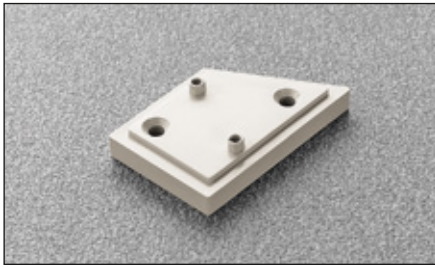

DP44XXGD - grey

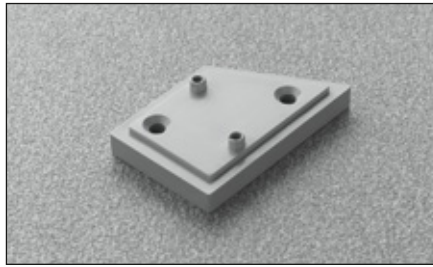

Right spacer H = 4.8 mm.

Packing
Boxes 300 pcs.

DP44XXBS - beige

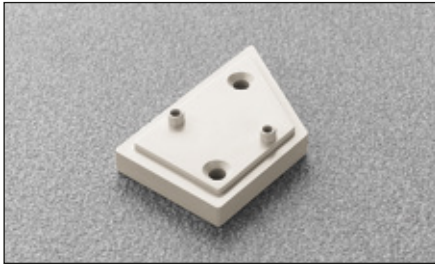

DP44XXGS - grey

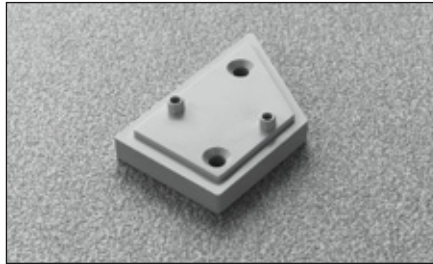

Left spacer H = 4.8 mm.

Packing
Boxes 300 pcs.

DP50SN0

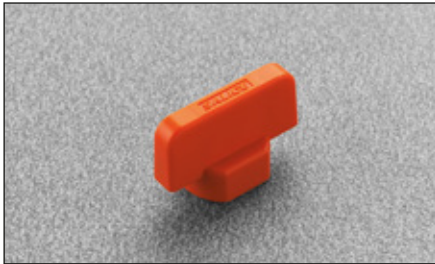

Orange insertion tool for retaining catch DP29SN_.



Push with depth and sideways adjustment

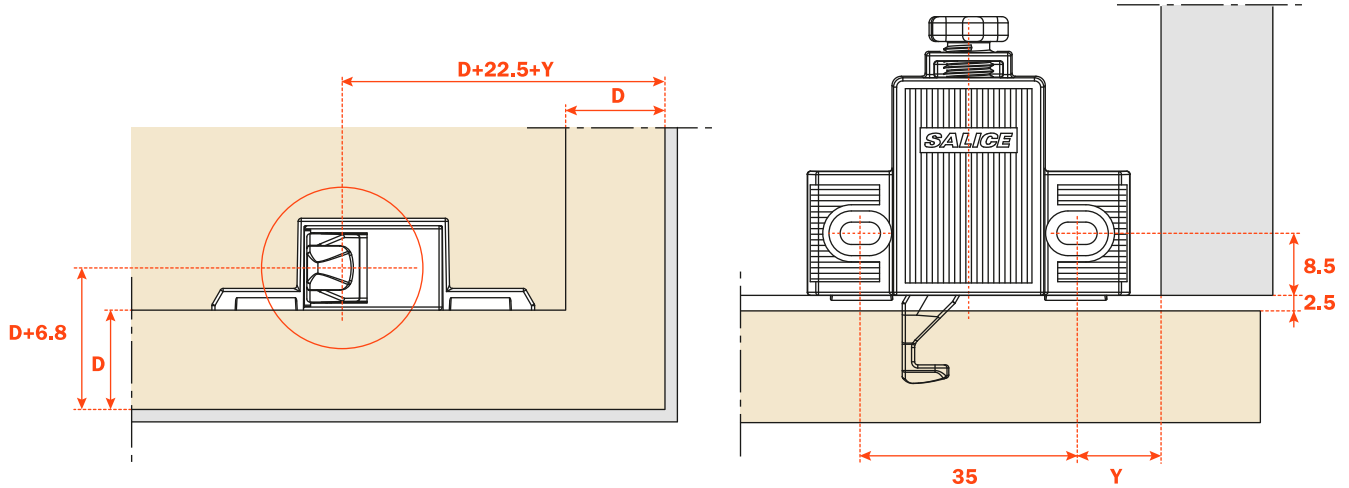

D = Door overlay on side and top of the cabinet
Y = min. 8.5 mm

Double Push with depth and sideways adjustment

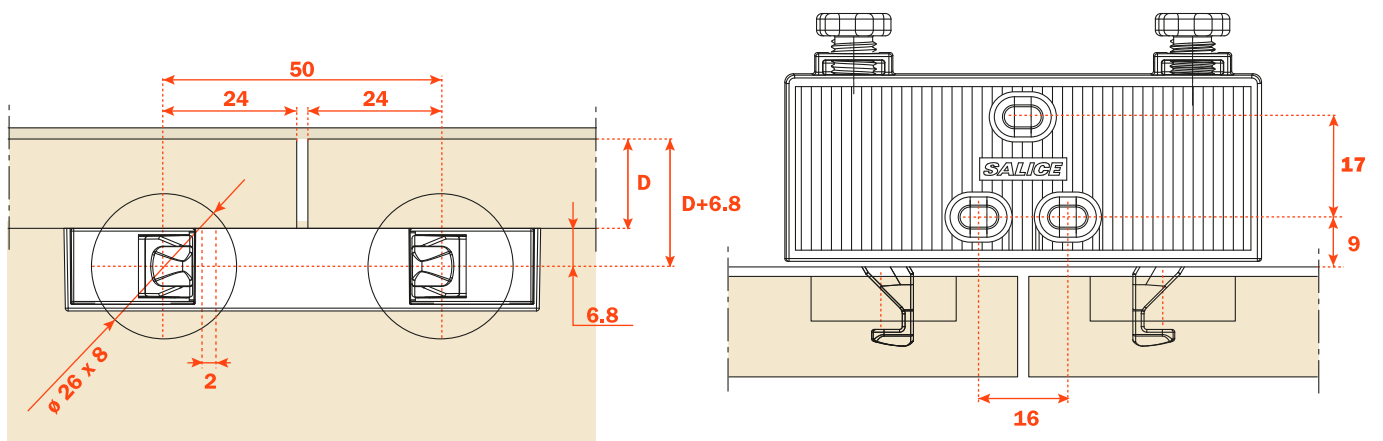

Fulloverlay door

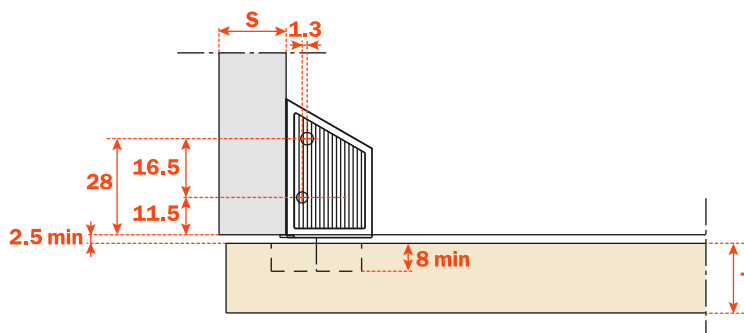
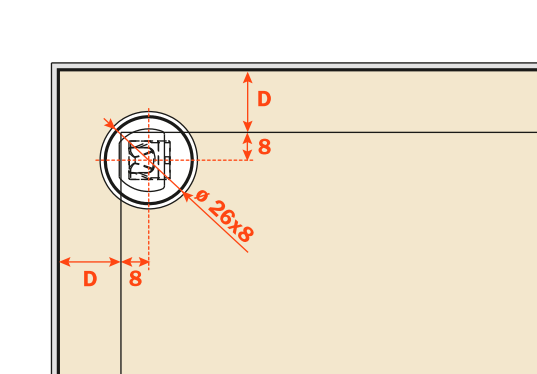

D = Door overlay on side and top of the cabinet
Drilling distance of retaining catch = D + 8

Special assemblies

$$\begin{aligned}
 A &= X - D + 4.5 \\
 P &= X - D + 10.8 \\
 X \text{ min} &= D + 8 \\
 \\
 A &= 26 - 18 + 4.5 = 12.5 \\
 P &= 26 - 18 + 10.8 = 18.8 \\
 X \text{ min} &= 18 + 8 = 26
 \end{aligned}$$

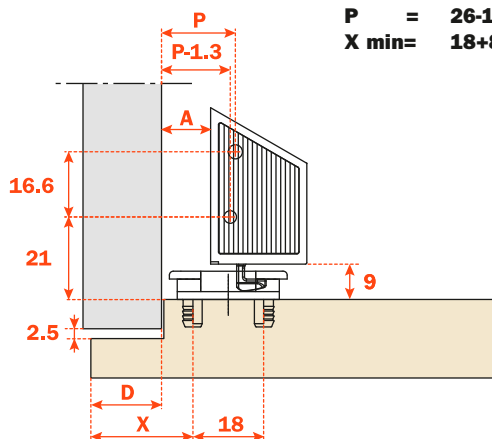
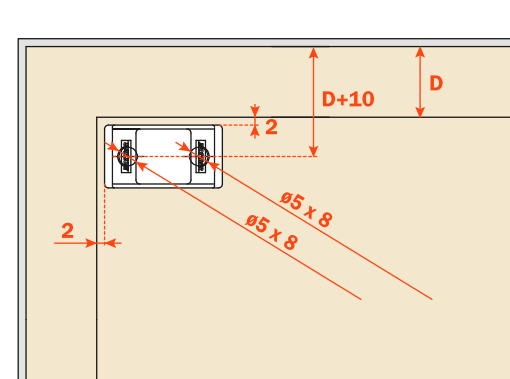

D = Door overlay on side and top of the cabinet

Inset door

$$\begin{aligned}
 P &= 14.8 + A \\
 P1 &= 36.8 + T \\
 P2 &= P - 1.3 \\
 P3 &= P1 - 16.5
 \end{aligned}$$

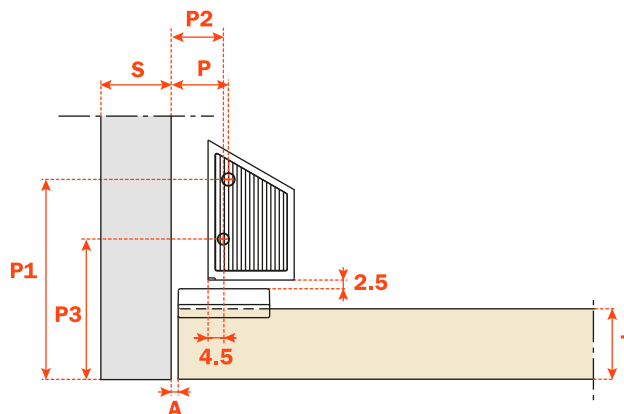
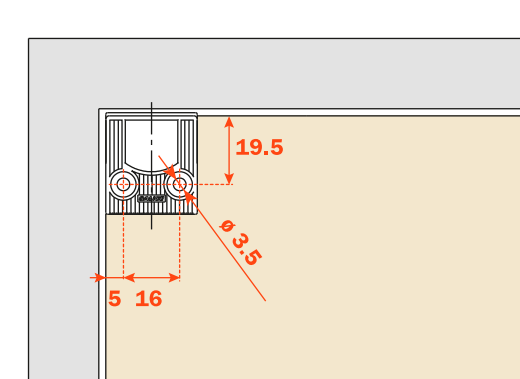

Mechanical Push - Drilling for aluminium frame doors

Profile min. 17 mm/max 35 mm

- D** = Door overlay on side and top of the cabinet
- F** = Drilling distance of retaining catch = $D + 8$
- X** = Relative to the distance to the corner of the profile
- P** = Fixing distance of PUSH = $X - D + 1.3$

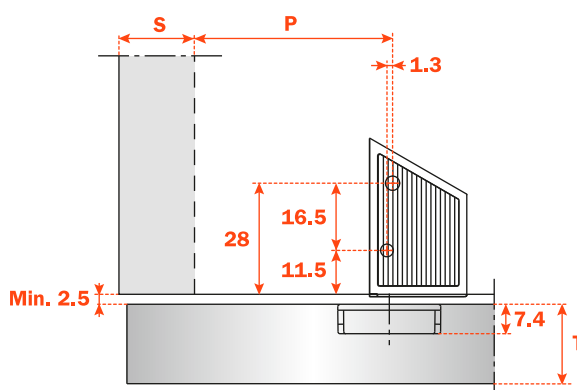
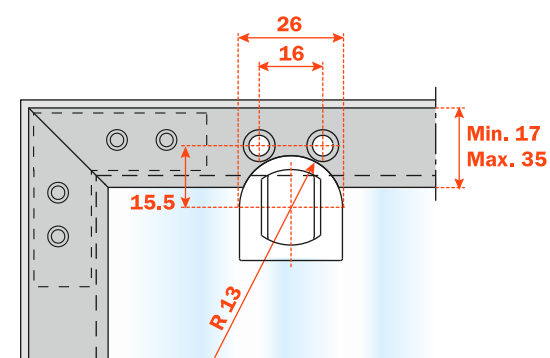
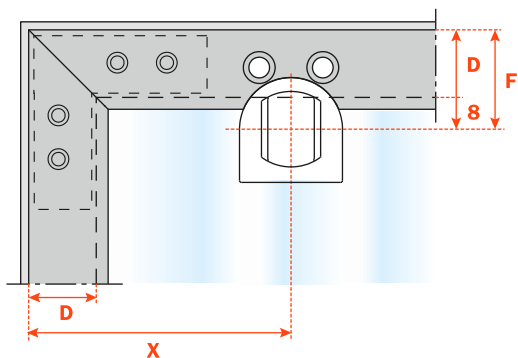

Profile min. 35 mm/max. 45 mm

- D** = Door overlay on side and top of the cabinet
- F** = Drilling distance of retaining catch = $D + 8$
- X** = Relative to the distance to the corner of the profile
- P** = Fixing distance of PUSH = $X - D + 1.3$

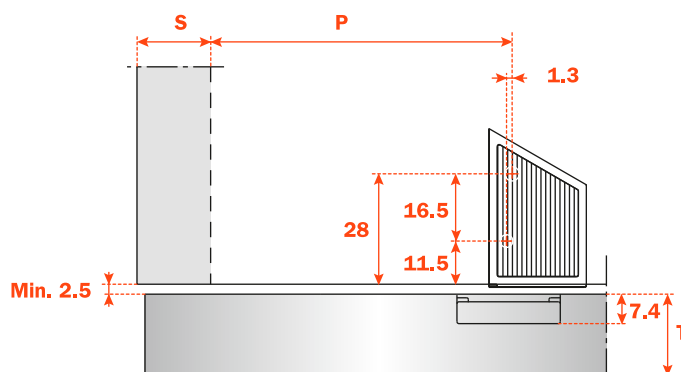
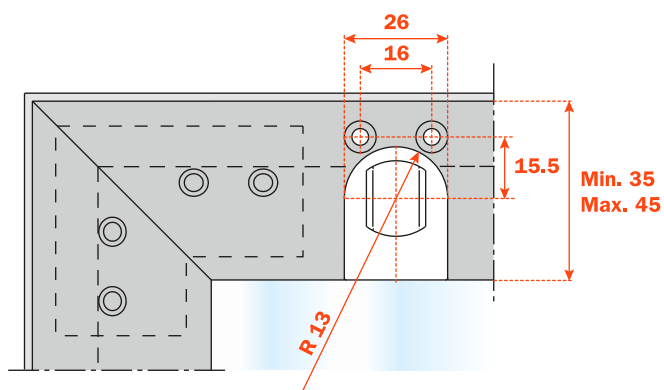
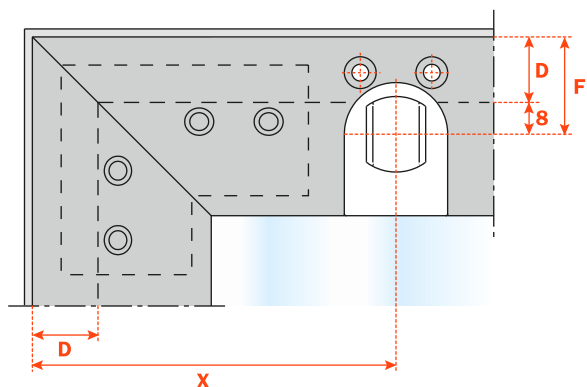

Profile with corner connector D206BS5

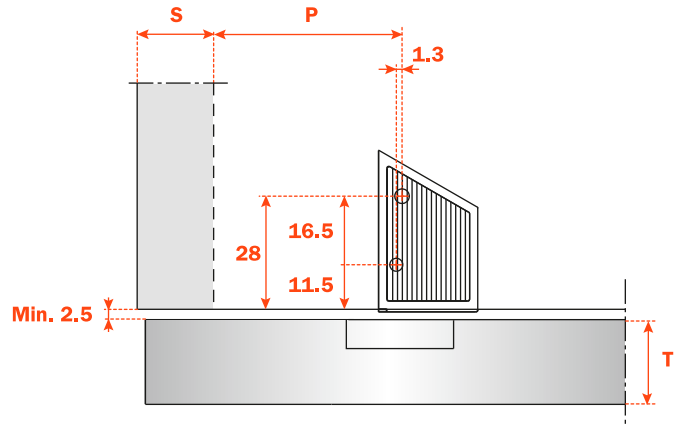
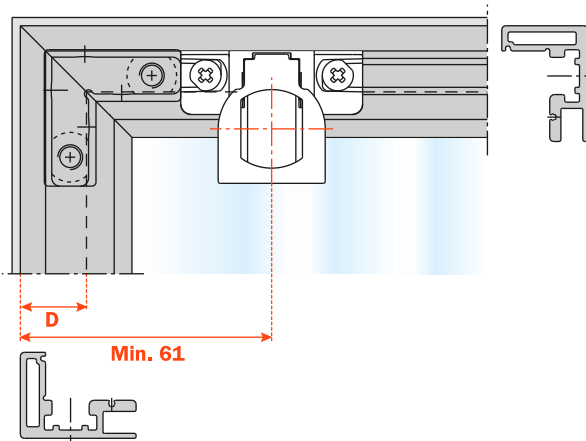

- D = Door overlay on side and top of the cabinet**
- P = Fixing distance of PUSH = 61 (min) - D + 1.3**

Profile with corner connector D206BS5L

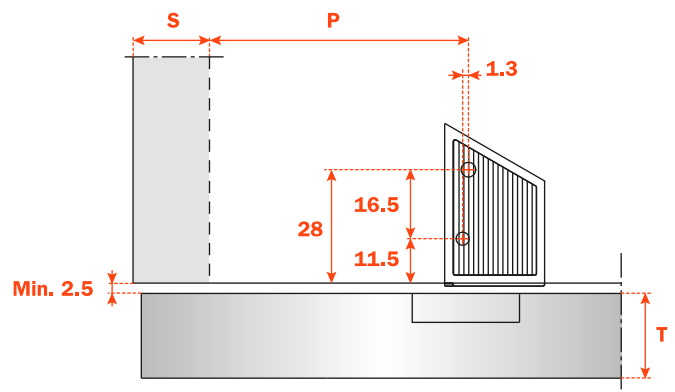
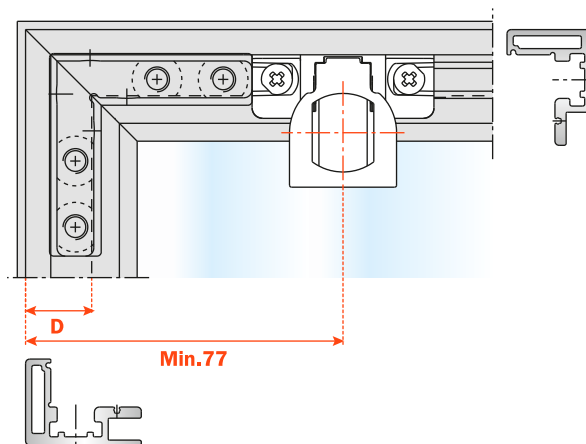

- D = Door overlay on side and top of the cabinet**
- P = Fixing distance of PUSH = 77 (min) - D + 1.3**

Magnetic Push



Magnetic Push - Release device to be recessed and retaining catches

DPMSNB - beige



DPMSNG - grey



Release device.
ø 10 mm, 40 mm length.

Packing

Boxes 250 pcs.
Cartons 1.500 pcs.

DPASNB - beige



DPASNG - grey



Release device to be used to increase the magnetic holding strength. It must always be used together with the DPM. The suggested position of the DPA is the point of pressure on the door. The DPA can be positioned at any point along the opening edge of the door. ø 10 mm, 40 mm length.

Packing

Boxes 250 pcs.
Cartons 1.500 pcs.

DP28SN9



Retaining catch to be inserted.
ø 11.5 mm.

Packing

Boxes 250 pcs.

DP38XX91



Retaining catch with adhesive.
20x14 mm.

Packing

Boxes 250 pcs.

DP39XXG

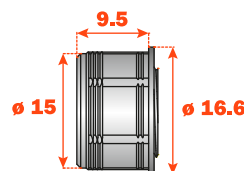

Adjustable magnetic retaining.
ø16.6 mm

Packing

Boxes 250 pcs.

SP44XX

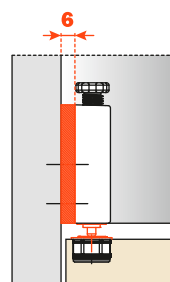

Spacer for inset door to be used together with DP82XX_R.

SP44XXG = grey
SP44XXB = beige

Packing

Boxes 250 pcs.

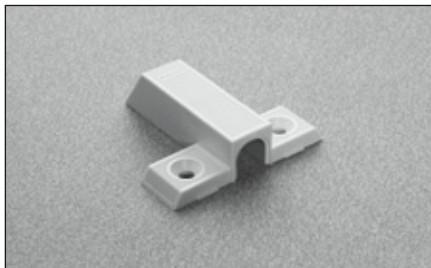
DP80SNBR - beige**DP80SNGR** - grey

Plastic adapter for release device.
To be fixed with wood screws.
7.5x32 mm drilling.
Without assembly stop devices.
DP81SN_R = To be fixed with Euro screws.

Packing

Boxes 500 pcs.
Pallets 12.000 pcs.

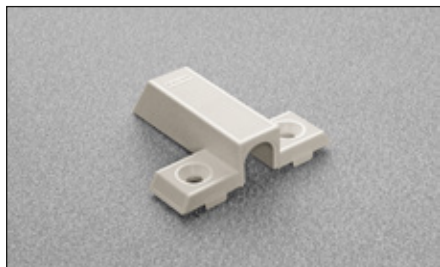
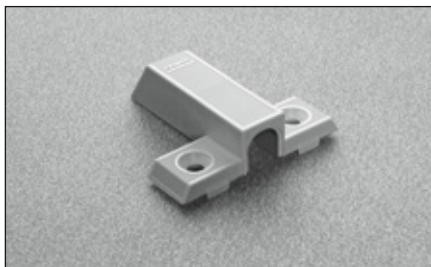
DP80SNB - beige**DP80SNG** - grey

Plastic adapter for release device.
To be fixed with wood screws.
7.5x32 mm drilling.
With assembly stop devices.
DP81SN_ = To be fixed with Euro screws.

Packing

Boxes 500 pcs.
Pallets 12.000 pcs.

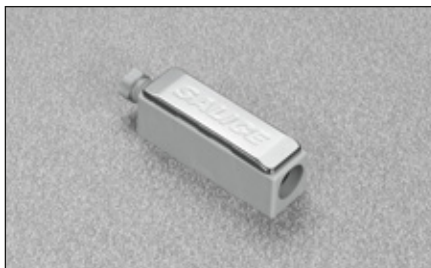
DP82XXBR - beige**DP82XXGR** - grey

Adjustable longitudinal plastic adapter for release device.
To be fixed with wood screws.
8+16 mm drilling.
Without assembly stop devices.

Caps to be ordered separately.

Packing

Boxes 500 pcs.
Pallets 12.000 pcs.

DP83XXBR - beige**DP83XXGR** - grey

Adjustable double plastic adapter for release device.
To be fixed with wood screws.
8+32 mm drilling.
Without assembly stop devices.

Cover caps to be ordered separately.

Packing

Boxes 500 pcs.
Pallets 12.000 pcs.

DP84SNBR - beige**DP84SNGR** - grey

Adjustable plastic adapter for release device.
To be fixed with wood screws.
8x32 mm drilling.
Without assembly stop devices.

Packing

Boxes 500 pcs.
Pallets 12.000 pcs.

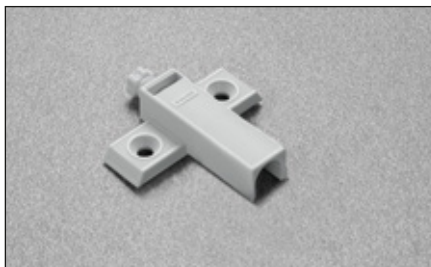
DP85SNBR - beige**DP85SNGR** - grey

Adjustable plastic adapter for release device.
To be fixed with wood screws.
37x32 mm drilling.
Without assembly stop devices.

Packing

Boxes 500 pcs.
Pallets 12.000 pcs.

Application of the release device to be recessed

Drill a hole \varnothing 10 mm and min. 40 mm depth in the top, the side or the base panel of the cabinet.

Insert the release device into the hole.

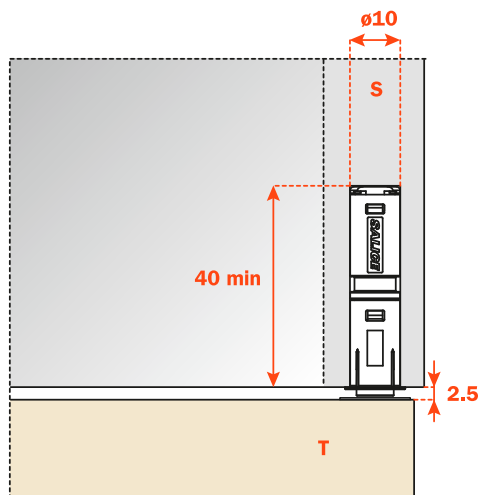

Release device application with adapter (DP82SN_R).

Insert the release device frontally into the adapter.

Place the adapter to the top, the side or the base panel of the cabinet, using the drilling value of 8+16 mm for final positioning.

For inset door it is essential to use the spacer SP44XX_.

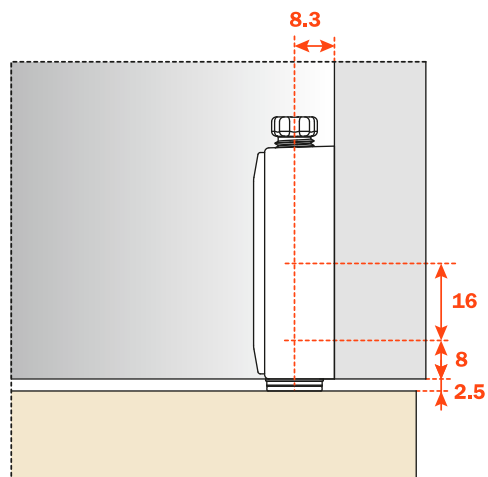

Release device application with spacer for inset door (DP82SN_R + SP44XX_).

For inset door it is essential to use the spacer SP44XX_.

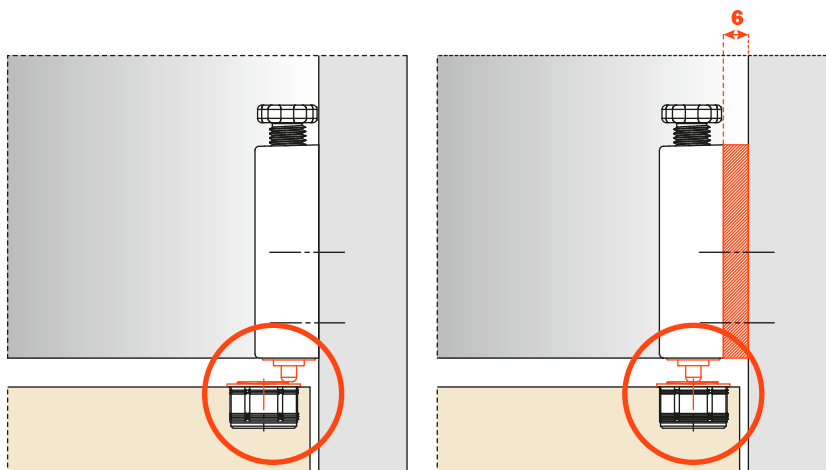

Release device application with adapter (DP83XX_R).

Insert the release device frontally into the adapter.
Place the adapter to the top, the side or the base panel of the cabinet, using the drilling value of 8+32 mm for final positioning.

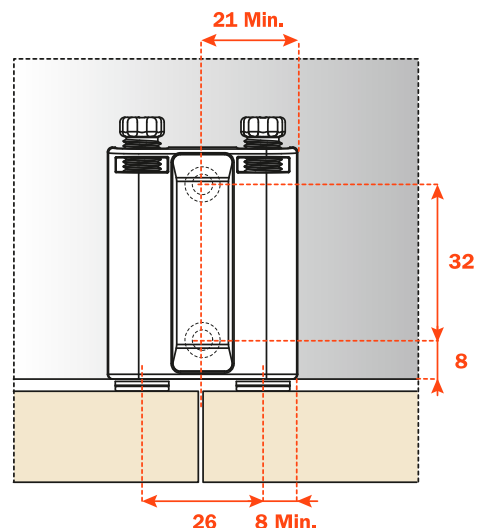

Release device application with adapter (DP80SN_ and DP84SN_R).

Insert the release device into the adapter.
Place the adapter to the top, the side or base panel of the cabinet, using the drilling value of 8x32 mm for final positioning.

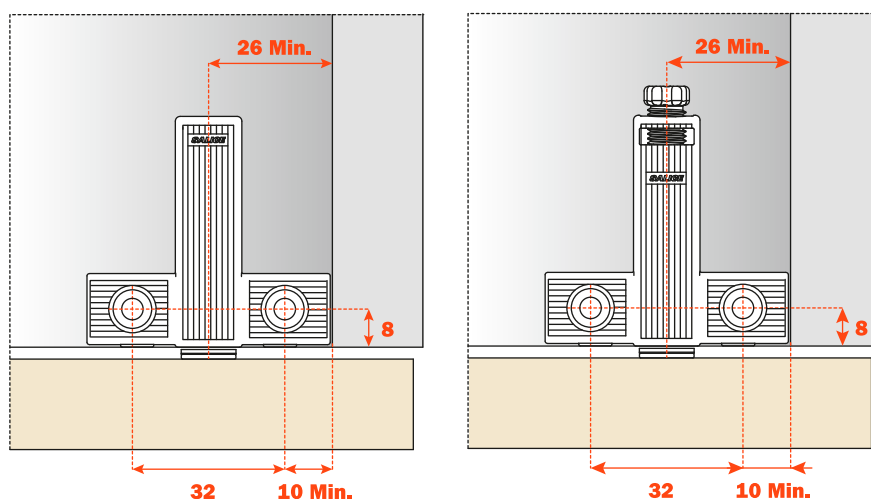

Release device application with adapter (DP85SN_R).

Insert the release device into the adapter.
Place the adapter to the top, the side or base panel of the cabinet, using the drilling value of 37x32 mm for final positioning.

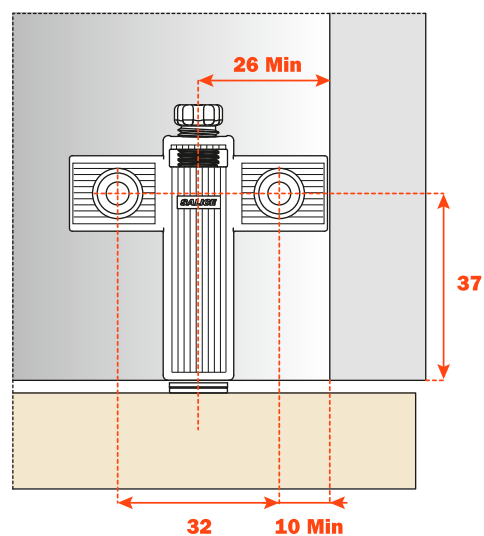

1 - Retaining catch with adhesive strip

Apply the retaining catch to the magnetic release device.

Remove the protective strip from the adhesive.

Close the door.

In this way the retaining catch is positioned on the door.

Reopen the door and apply a firm pressure to the retaining catch to ensure a correct installation.

ATTENTION:

For a correct application and to ensure optimal endurance, we suggest these guidelines are followed:

- 1** - clean and degrease the door surface where the retaining catch is to be installed;
- 2** - remove the protective strip from the adhesive;
- 3** - place the retaining catch in position, in a place that is at room temperature $\geq 10^{\circ}$ and apply a firm pressure for 10-15 seconds.

After few seconds from the installation the retaining catch is suitable for the use. After 24h the max. hold is attained.

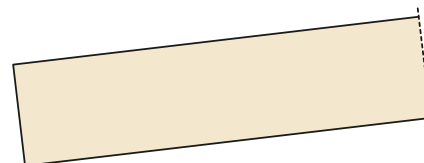
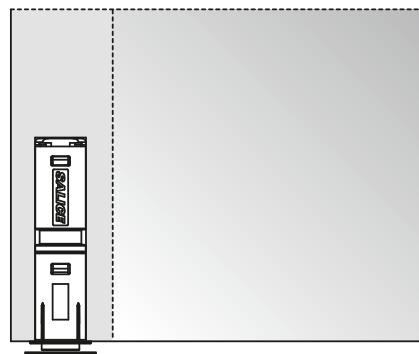

2 - Retaining catch to be inserted

Apply the retaining catch to the magnetic release device.

Close the door.

The point of the retaining catch will show where to insert it.

Reopen the door and press the retaining catch.

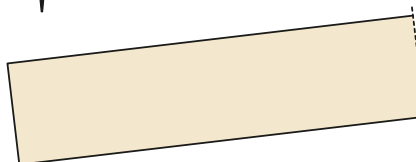
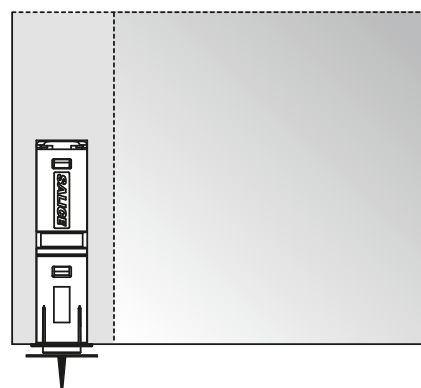

3 - Magnetic retaining catch to be inserted

The retaining catch DP39 is itself magnetic and together with the magnetism of the release device DPM considerably increase (30%) the holding strength of the door against the cabinet side, thus avoiding accidental openings.

For the installation it is necessary to drill a hole $\varnothing 15$ mm and 11 mm depth in the door.

Depth adjustment from -0.5 mm to +2.5 mm.

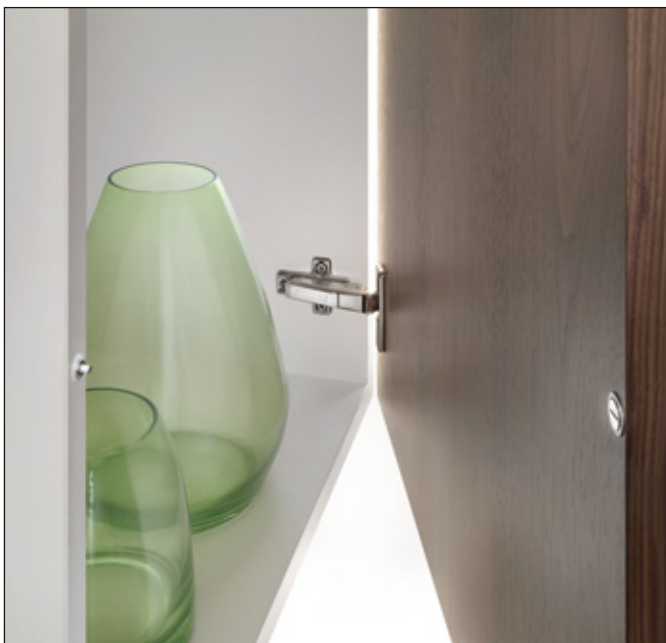
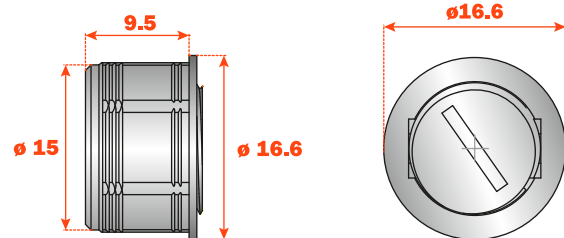
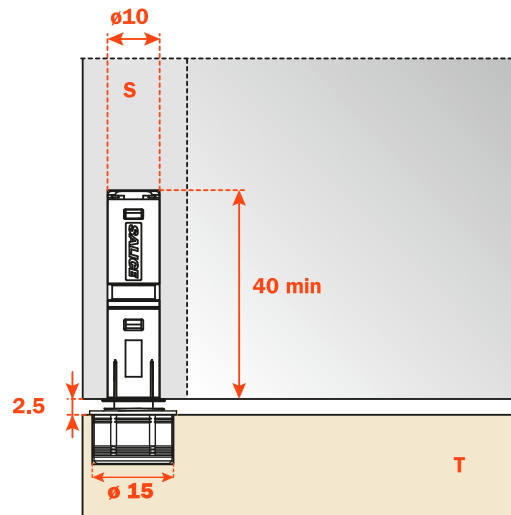

Adjustment -0.5 mm

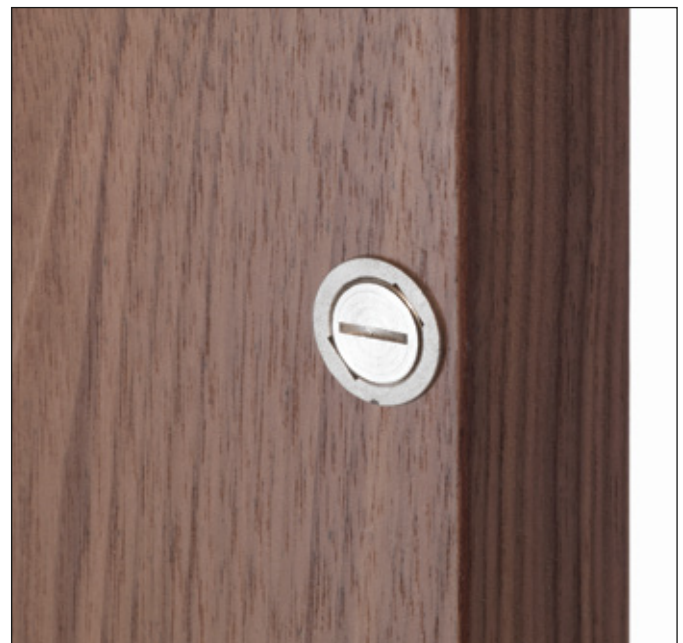

Adjustment +2.5 mm



Push - Series 200 hinges

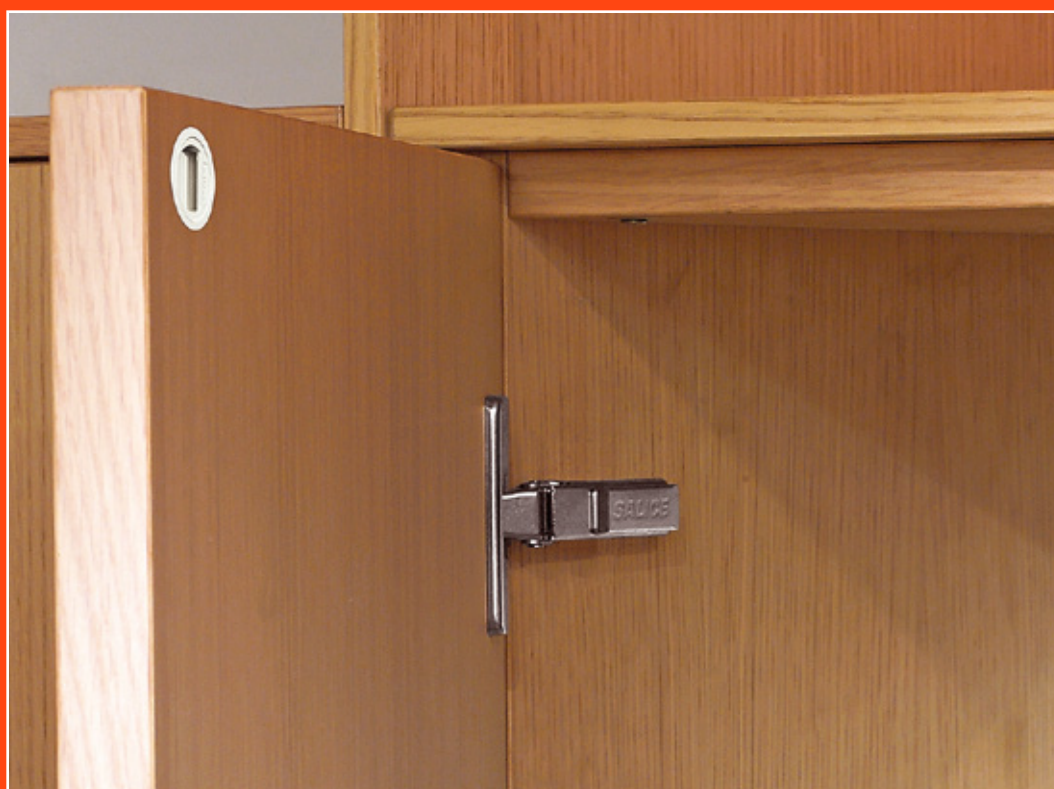

The Series 200 make up an integrated system of hinges developed to provide a solution to any situation involving concealed hinges.

Bright nickel plated steel cup and arm.
Dimensions of the \varnothing 35 mm cup.

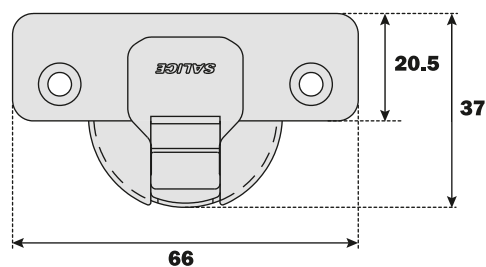

Constant "L" value of 0.7 mm (it does not change during side adjustment).

Approx. number of hinges required according to the door dimension and weight.

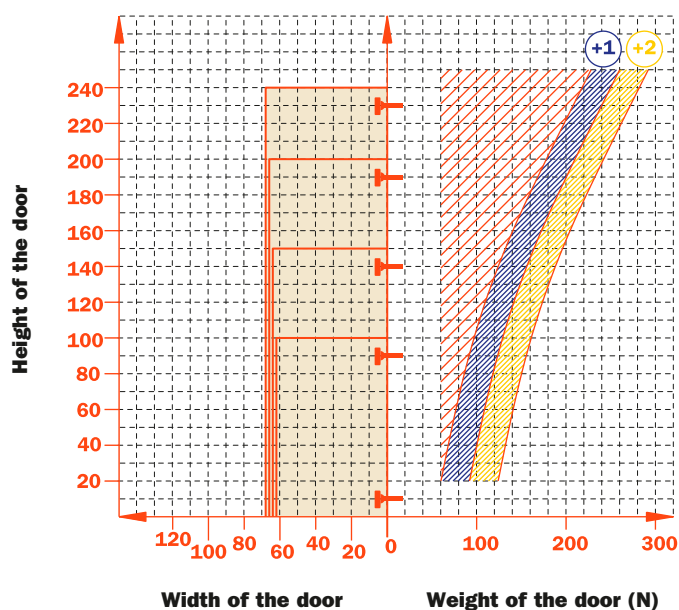

Adjustments

Compensating side adjustment from - 1.5 to + 4.5 mm.
Height adjustment \pm 2 mm.
Depth adjustment with Series 200 mounting plates + 2.8 mm.
Depth adjustment with Domi snap-on mounting plates from - 0.5 mm to + 2.8 mm.
Anti-sliding safety stop.

Mounting plates

Symmetrical and asymmetrical bright nickel plated steel or die-cast Series 200 mounting plates.
Snap-on assembly on Domi mounting plates.
Positioning with pre-determined stop on traditional Series 200 mounting plates.

N.B. : Use POZIDRIVE No. 2 screwdrivers for all screws.



Wood screw	A	A	A	P	P	P	U	U	U

Rapido	6	6	6	7	7	7	2	2	2
Dowel	B	B	B	R	R	R	W	W	W
Logica	I	I	I	J	J	J	Q	Q	Q

Use this table to identify the available drillings and fixings.
Fill the third position of the hinge code number with the letter or the number corresponding to your choice. I.e.: C2_PA99.

↑
 Fill this position with the chosen letter or number.

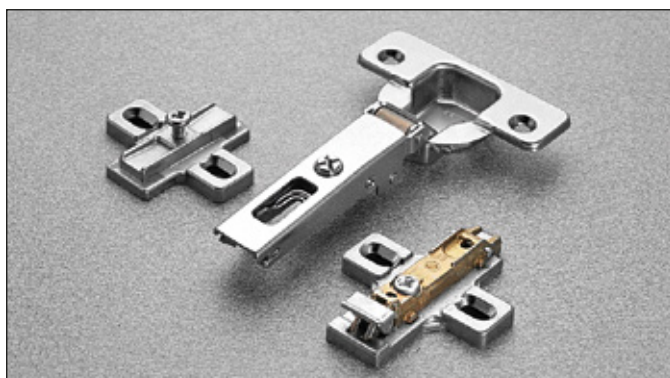

Technical information

Push hinges are equipped with a special spring that acts to open the door independently of the release device.

For thick doors up to 35 mm, with special profiles.
11 mm deep metal cup.
94° opening.

Possible drilling distance on the door (K): from 3 to 9 mm.
Compatible with all traditional Series 200 mounting plates
and with all Domi snap-on mounting plates.

Space needed to open the door

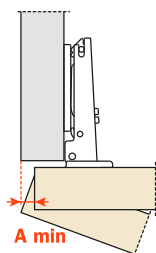

T=	19	20	21	22	23	24	25	26	27	28	29	30	31	32	33	34	35
K=3 A=	0.1	0.2	0.3	0.4	0.5	0.7	0.8	1.0	1.6	2.6	3.5	4.5	5.4	6.4	7.4	8.3	9.3
K=4 A=	0.1	0.2	0.3	0.4	0.5	0.7	0.8	1.0	1.2	1.9	2.8	3.8	4.7	5.7	6.6	7.6	8.6
K=5 A=	0.1	0.2	0.3	0.4	0.5	0.7	0.8	1.0	1.2	1.4	2.2	3.1	4.1	5.0	5.9	6.9	7.8
K=6 A=	0.1	0.2	0.3	0.4	0.5	0.6	0.8	1.0	1.2	1.4	1.7	2.6	3.5	4.4	5.3	6.2	7.2
K=7 A=	0.1	0.2	0.3	0.4	0.5	0.6	0.8	1.0	1.1	1.3	1.6	2.1	3.0	3.8	4.7	5.6	6.5
K=8 A=	0.1	0.2	0.3	0.4	0.5	0.6	0.8	0.9	1.1	1.3	1.6	1.8	2.5	3.3	4.2	5.1	6.0
K=9 A=	0.1	0.2	0.3	0.4	0.5	0.6	0.8	0.9	1.1	1.3	1.5	1.8	2.1	2.9	3.7	4.6	5.4

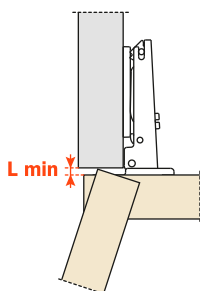

K=	3	4	5	6	7	8	9
L=	0.0	0.0	0.0	0.0	0.0	0.3	1.3

The above values are calculated on the assumption that the doors have square edges. They are reduced if the doors have radiussed edges.

Projection of the door

Projection of the door from the cabinet side at the max. opening. The figures are based on a straight arm hinge, H=0 mm thickness of mounting plate and K value = 3 mm.

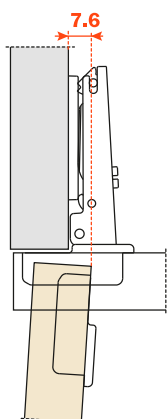

"C" value

With this formula you can obtain the max. thickness of the moulded door that can be opened without touching adjacent carcass sides, doors or walls, whilst bearing in mind the above L-K-T values.

$$C = 23 + K + A$$

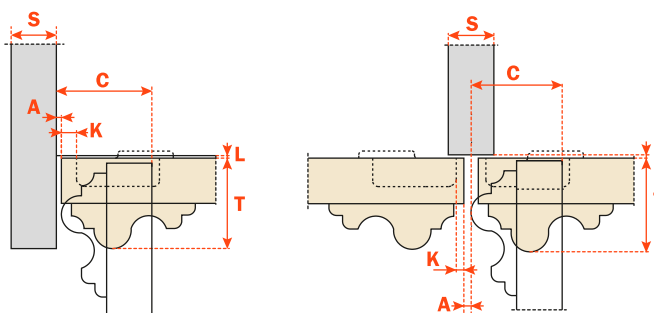

Packing

Boxes 300 pcs.
Pallets 7.200 pcs.

Use these formulas to determine the type of hinge arm, the drilling distance "K" and the height of the mounting plate "H" which is necessary to solve each application problem.

Use the tables "Drillings and fixings" at page 29 to complete the code number of the desired hinge.

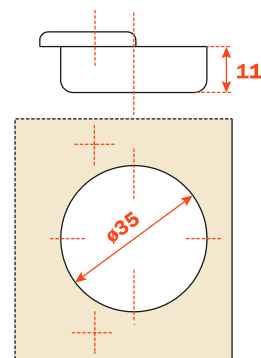

Arm 0

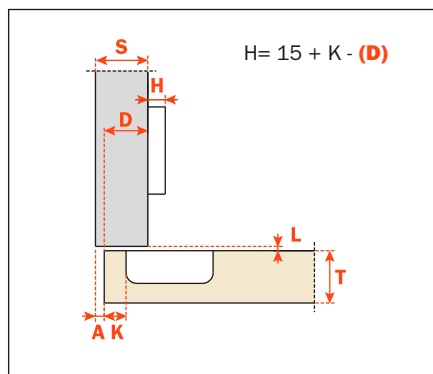

C2_VA99

Arm 5

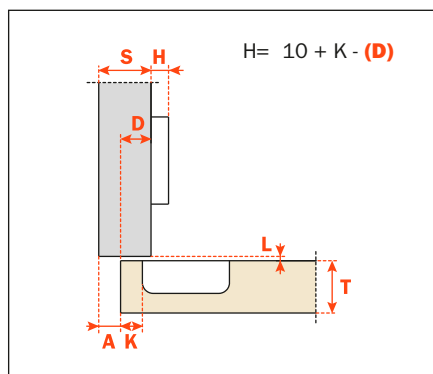

C2_VD99

Arm 9

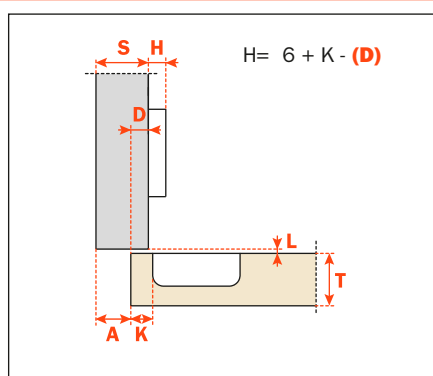

C2_VG99

Arm 17

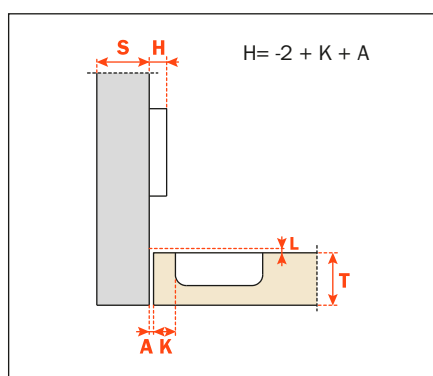

C2_VP99

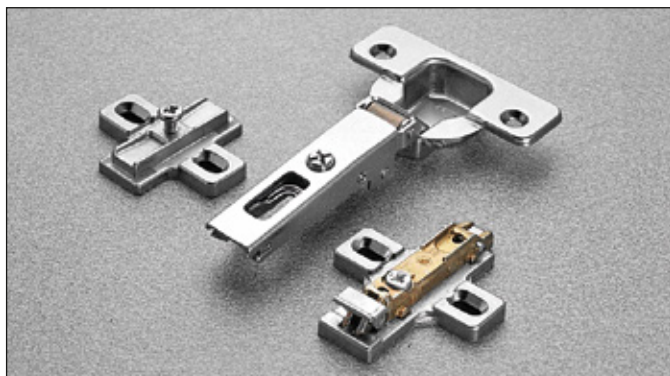

Technical information

Push hinges are equipped with a special spring that acts to open the door independently of the release device.

When a greater opening angle is required.
11 mm deep metal cup.

110° opening.

Possible drilling distance on the door (K): from 3 to 6 mm.
Compatible with all traditional Series 200 mounting plates and with all Domi snap-on mounting plates.

Space needed to open the door

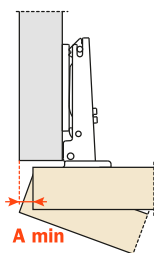

	T=	16	17	18	19	20	21	22	23	24	25	26
K=3	A=	0.5	0.7	0.9	1.2	1.5	1.8	2.4	3.7	5.1	6.5	7.8
K=4	A=	0.5	0.7	0.9	1.2	1.5	1.8	2.1	2.7	4.1	5.5	6.8
K=5	A=	0.5	0.7	0.9	1.2	1.5	1.8	2.1	2.6	3.1	4.1	5.4
K=6	A=	0.5	0.7	0.9	1.2	1.5	1.8	2.1	2.5	3.0	3.5	4.4

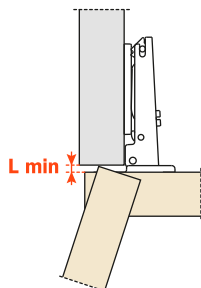

	T=	16	17	18	19	20	21	22	23	24	25	26
K=3	L=	0.0	0.0	0.0	0.0	0.2	0.5	0.8	1.1	1.4	1.7	1.9
K=4	L=	0.0	0.0	0.3	0.6	0.9	1.2	1.4	1.7	2.0	2.3	2.6
K=5	L=	1.1	1.3	1.6	1.8	2.1	2.3	2.6	2.9	3.1	3.4	3.6
K=6	L=	2.0	2.3	2.5	2.8	3.1	3.3	3.6	3.8	4.1	4.3	4.6

The above values are calculated on the assumption that the doors have square edges. They are reduced if the doors have radiussed edges.

Projection of the door

Projection of the door from the cabinet side at the max. opening. The figures are based on a straight arm hinge, H=0 mm thickness of mounting plate and K value = 3 mm.

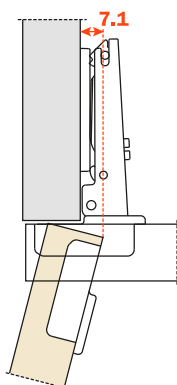

"C" value

With this formula you can obtain the max. thickness of the moulded door that can be opened without touching adjacent carcass sides, doors or walls, whilst bearing in mind the above L-K-T values.

$$C = 20 + K + A$$

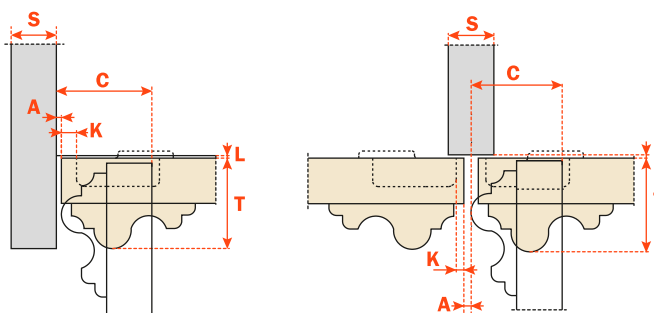

Packing

Boxes 300 pcs.
Pallets 7.200 pcs.

Use these formulas to determine the type of hinge arm, the drilling distance "K" and the height of the mounting plate "H" which is necessary to solve each application problem.

Use the tables "Drillings and fixings" at page 29 to complete the code number of the desired hinge.

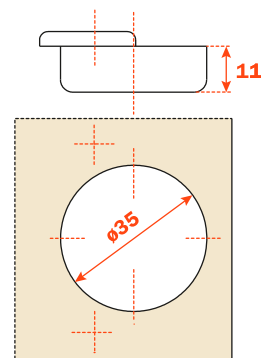

Arm 0

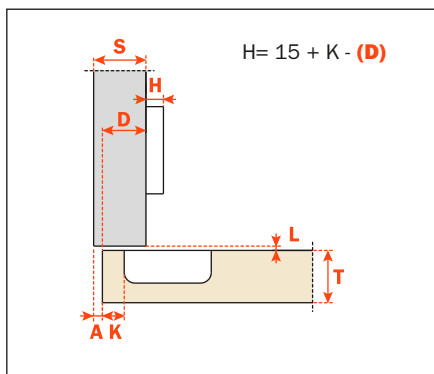

C2_PA99

Arm 5

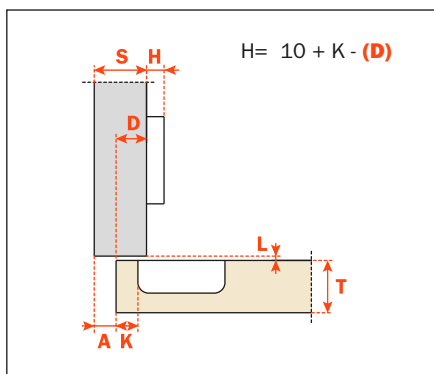

C2_PD99

Arm 9

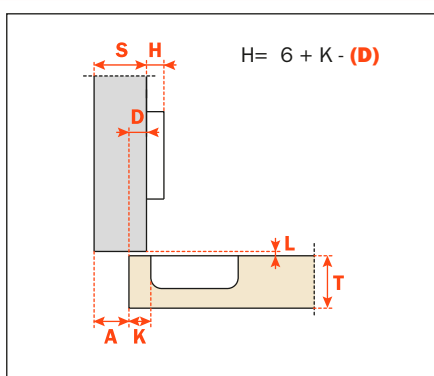

C2_PG99

Arm 17

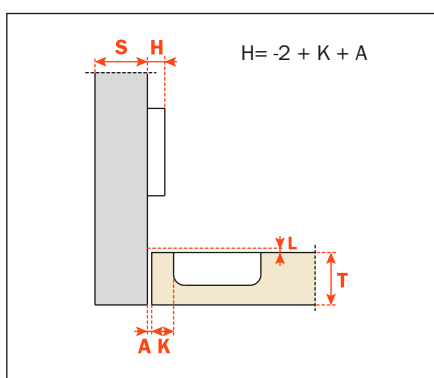

C2_PP99

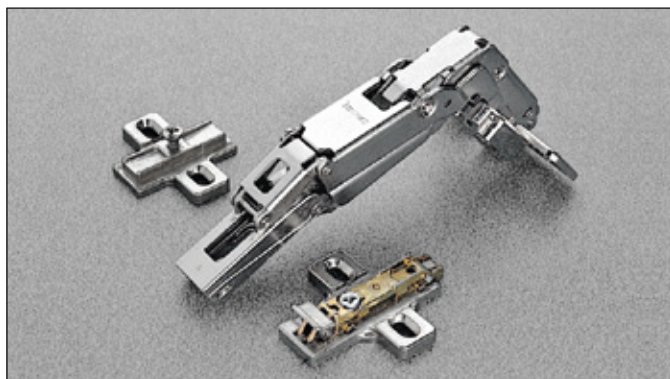

Technical information

Push hinges are equipped with a special spring that acts to open the door independently of the release device.

For thick doors min. 10 mm.
 8 mm deep die-cast cup.
 With 0 mm door protrusion only with straight arm hinge.
 155° opening.
 Possible drilling distance on the door (K): from 3 to 8 mm.
 Compatible with all traditional Series 200 mounting plates and with all Domi snap-on mounting plates.

Space needed to open the door

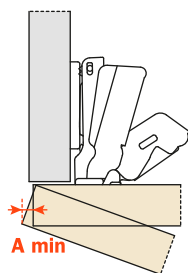

	T=	16	18	20	22
K=3	A=	0.0	0.0	0.3	1.2
K=4	A=	0.0	0.4	0.4	1.3
K=5	A=	0.0	0.1	0.5	1.6
K=6	A=	0.0	0.1	1.2	3.0
K=7	A=	0.0	0.1	0.7	2.5
K=8	A=	0.0	0.1	0.6	1.9

The above values are calculated on the assumption that the doors have square edges. They are reduced if the doors have radiussed edges.

“C” value

For spaces with removable components. The door opens at 90° with lateral door protrusion of 2 mm. The figures are based on a straight arm hinge and H=0 thickness of mounting plate.

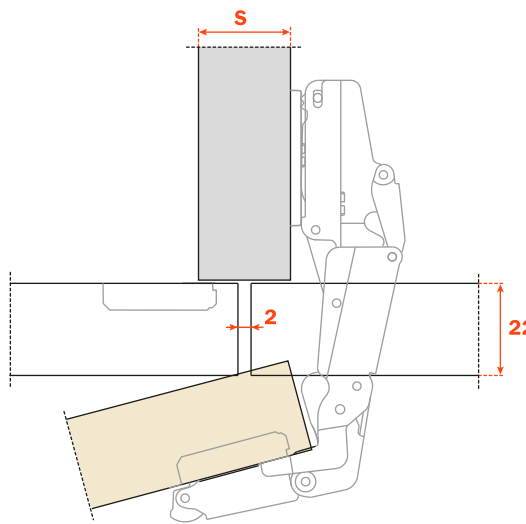
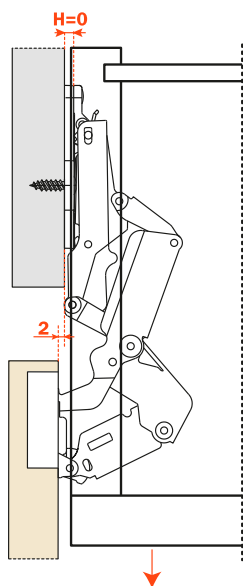

Packing

Boxes 100 pcs.
Pallets 2.400 pcs.

Use these formulas to determine the type of hinge arm, the drilling distance "K" and the height of the mounting plate "H" which is necessary to solve each application problem.

To limit the opening of the hinge, see page 59 chapter "Accessories".

Use the tables "Drillings and fixings" at page 29 to complete the code number of the desired hinge.

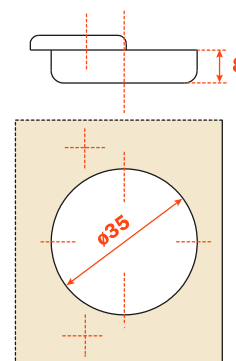

Arm 0

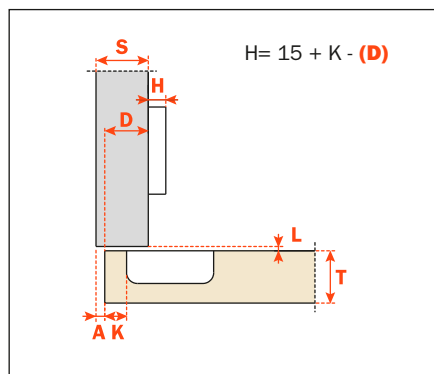

C2_UA99

Arm 5

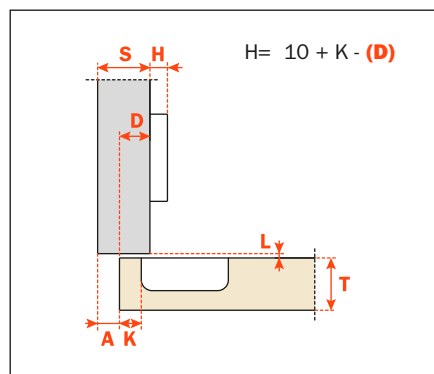
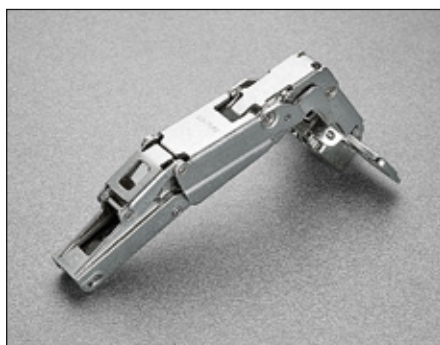

C2_UD99

Arm 9

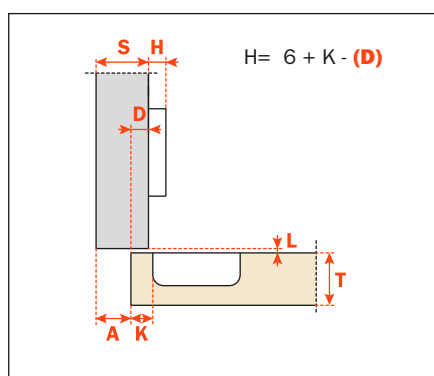

C2_UG99

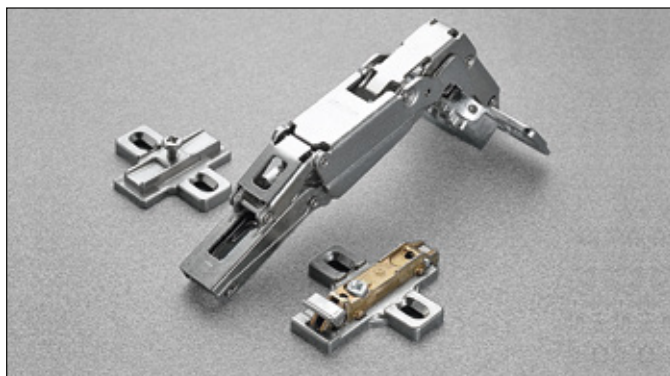

Technical information

Push hinges are equipped with a special spring that acts to open the door independently of the release device.

For thick doors up to 35 mm.
 Hinge with greater opening angle and reduced operating profile.
 11 mm deep die-cast cup.
 155° opening.
 Possible drilling distance on the door (K): from 3 to 9 mm.
 Compatible with all traditional Series 200 mounting plates and with all Domi snap-on mounting plates.

Space needed to open the door

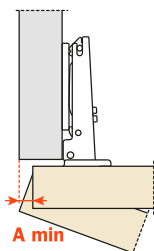

T=	26	27	28	29	30	31	32	33	34	35
K=3	A= 0.0	0.0	0.0	0.8	3.0	4.8	7.1	11.7	16.4	20.7
K=4	A= 0.0	0.0	0.0	0.8	2.5	4.0	6.2	10.6	15.0	19.7
K=5	A= 0.0	0.0	0.0	0.8	2.0	3.4	4.8	9.8	14.1	18.4
K=6	A= 0.0	0.0	0.0	0.8	1.5	2.8	4.2	8.7	13.2	17.8
K=7	A= 0.0	0.0	0.0	0.8	1.4	2.3	3.0	7.8	12.0	16.7
K=8	A= 0.0	0.0	0.0	0.2	0.9	1.9	2.7	7.0	11.2	15.7
K=9	A= 0.0	0.0	0.0	0.2	0.7	1.5	2.1	5.9	10.4	15.0

The above values are calculated on the assumption that the doors have square edges. They are reduced if the doors have radiussed edges.

“C” value

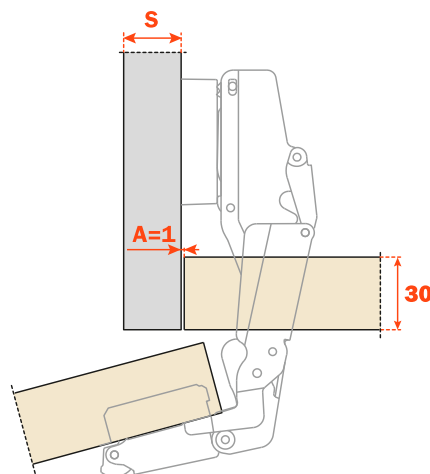
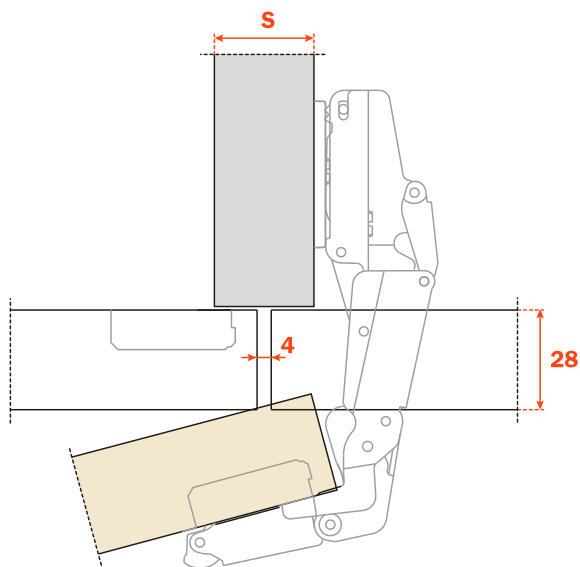

Packing

Boxes 100 pcs.
Pallets 2.400 pcs.

Use these formulas to determine the type of hinge arm, the drilling distance "K" and the height of the mounting plate "H" which is necessary to solve each application problem.

To limit the opening of the hinge, see page 59 chapter "Accessories".

Use the tables "Drillings and fixings" at page 29 to complete the code number of the desired hinge.

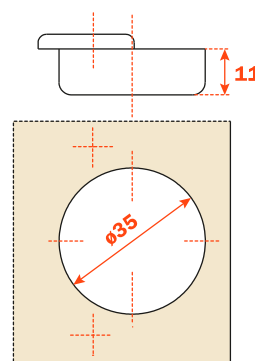

Arm 0

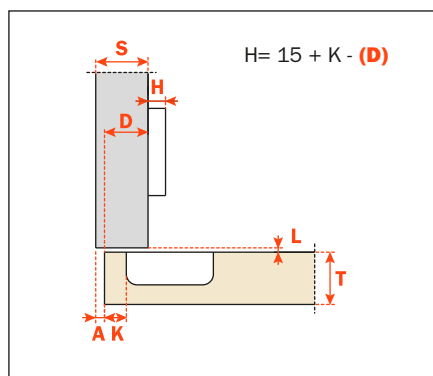

C2_TA99

Arm 5

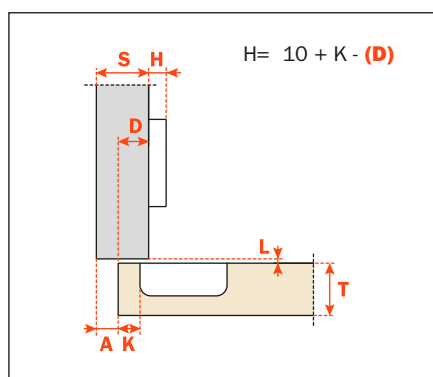

C2_TD99

Arm 9

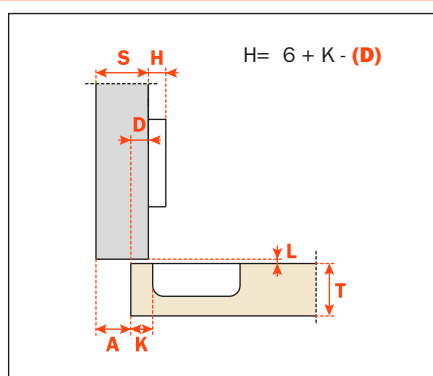

C2_TG99



Technical information

Push hinges are equipped with a special spring that acts to open the door independently of the release device.

Hinges for wooden doors with positive angled assembly.
 11 mm deep metal cup.
 94° opening.
 Possible drilling distance on the door (K): from 3 to 9 mm.
 Compatible with all traditional Series 200 mounting plates and with all Domi snap-on mounting plates.

Packing

Boxes 150 pcs.
 Pallets 3.600 pcs.

The solution of assembly problems where doors are mounted at a positive angle requires the verification of drilling distances by a practical trial. Please do not hesitate to consult our technical support department for assistance.

Use the tables "Drillings and fixings" at page 29 to complete the code number of the desired hinge.

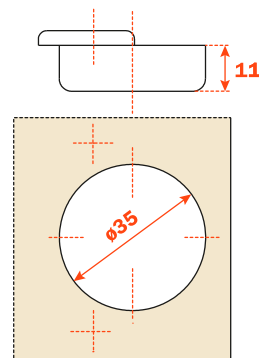

Arm **15°**

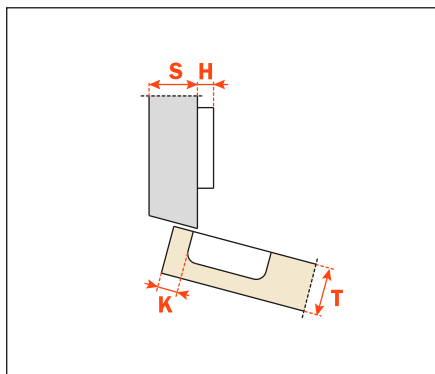

C2_VZ99

Arm **24°**

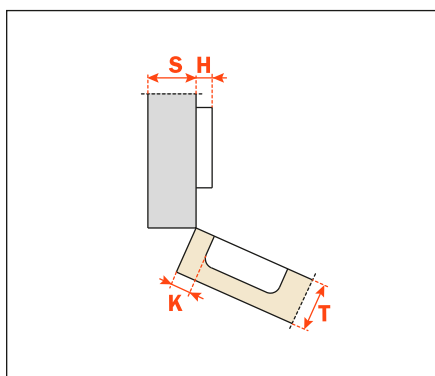

C2_VU99

Arm **30°**

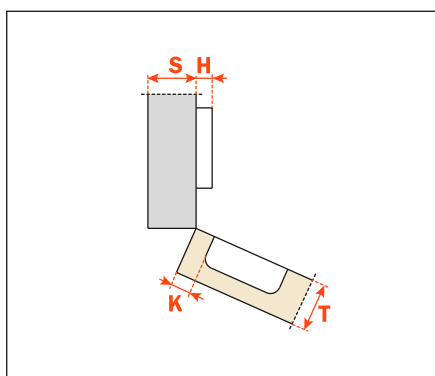

C2_VE99

Arm 30°

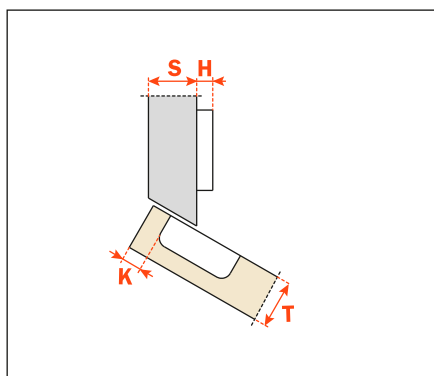

C2_VT99

Arm 37°

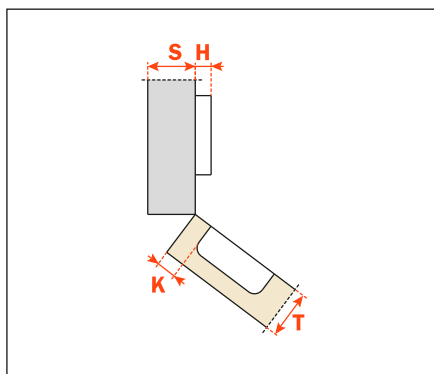

C2_VK99

Arm 45°

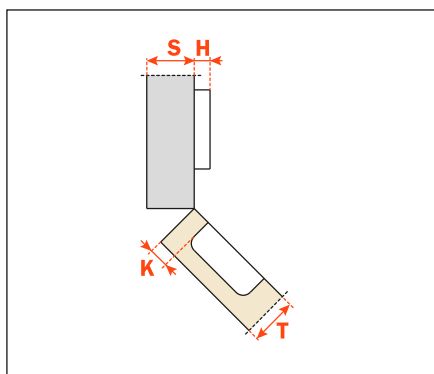

C2_VM99

Arm 45°

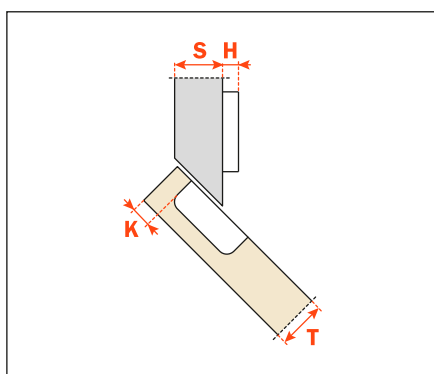

C2_VV99

Arm 45°

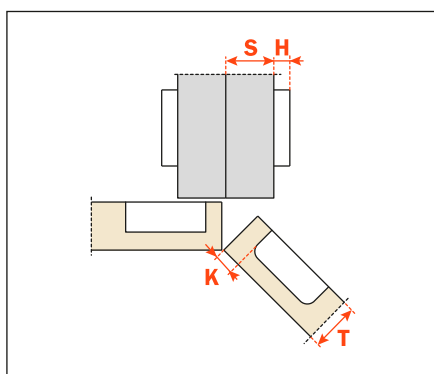

C2_VM99AC

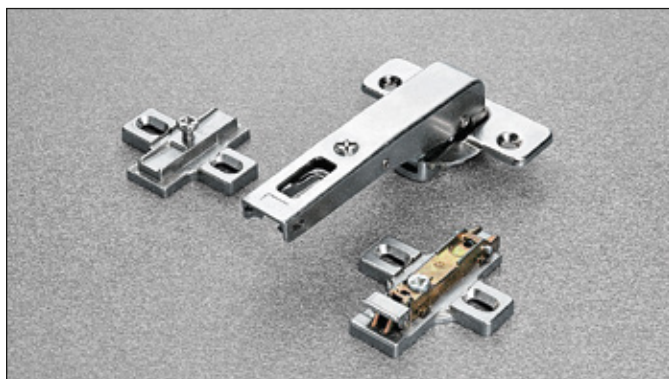

Technical information

Push hinges are equipped with a special spring that acts to open the door independently of the release device.

Crampon hinges.

For cabinet sides with 37x32 mm standard drilling.

11 mm deep metal cup.

94° opening.

Possible drilling distance on the door (K): from 3 to 9 mm.

Compatible with all traditional Series 200 mounting plates and with all Domi snap-on mounting plates.

Packing
Boxes 150 pcs.
Pallets 3.600 pcs.

E min:
61 mm for Series 200 mounting plates.
70 mm for Domi snap-on mounting plates.
74 mm for Domi snap-on mounting plates with back cam.

Use the tables "Drillings and fixings" at page 29 to complete the code number of the desired hinge.

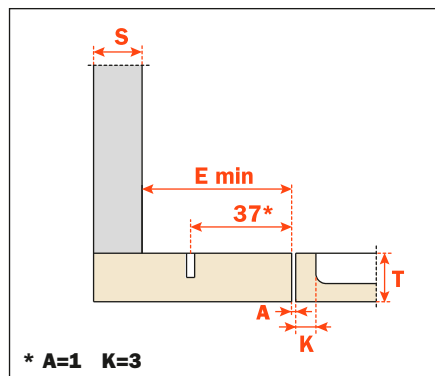
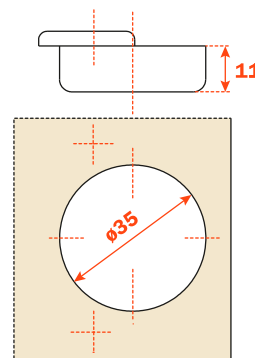

C2_VN99AC

Heights of mounting plates for every assembly.

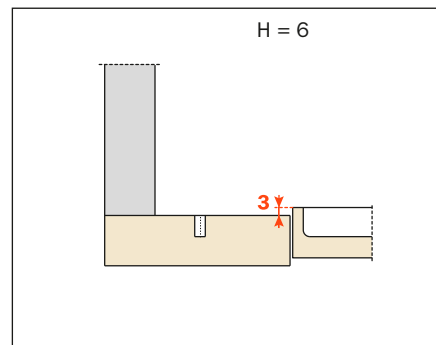
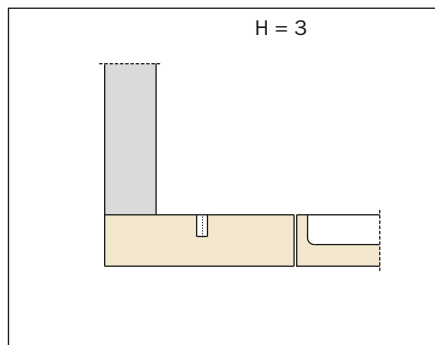
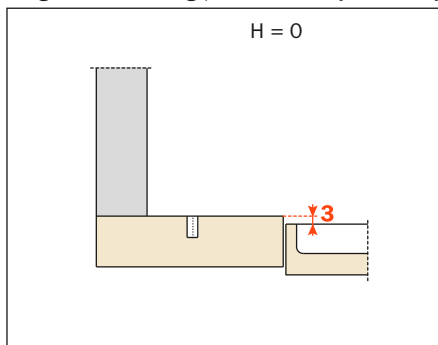

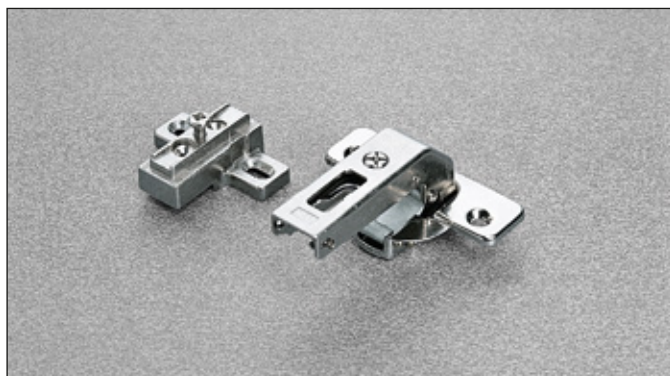

Technical information

Push hinges are equipped with a special spring that acts to open the door independently of the release device.

Crampon hinges.

For smaller spaces with 15x32 mm drilling.

11 mm deep metal cup.

94° opening.

Possible drilling distance on the door (K): from 3 to 9 mm.

Compatible with all traditional Series 200 mounting plates, 28x32 mm drilling.

NOT COMPATIBLE with Domi snap-on mounting plates.

Packing

Boxes 150 pcs.

Pallets 3.600 pcs.

Use the tables "Drillings and fixings" at page 29 to complete the code number of the desired hinge.

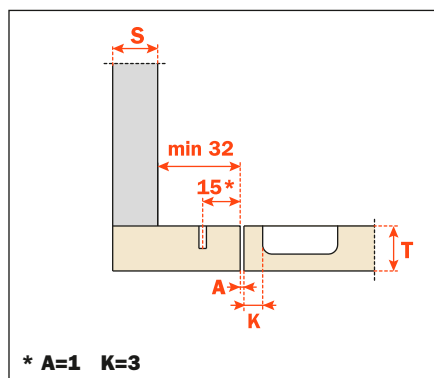
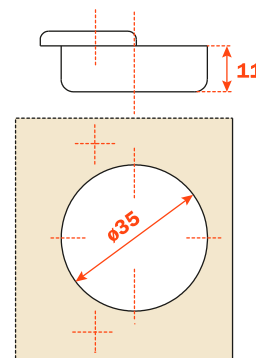

C2_VN99

Heights of mounting plates for every assembly.

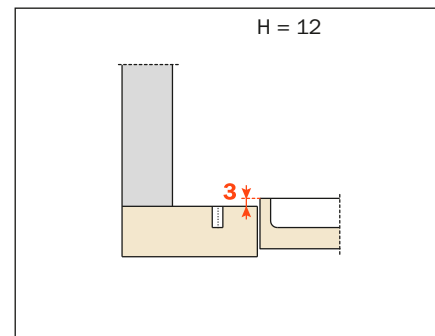
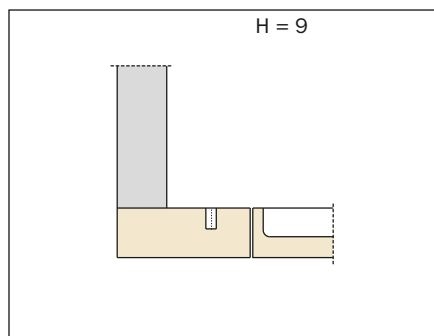
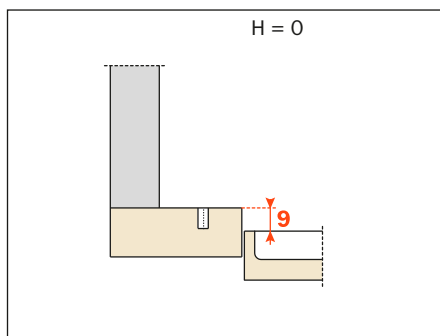

Push - Hinges for metal profiles





Technical information

Push hinges are equipped with a special spring that acts to open the door independently of the release device.

Hinges for the Practical system have been developed for use with special metal profiles. The particular fixing system does not require any profile working. The hinge can be therefore assembled at any point of the frame.

105° opening.

Compatible with all traditional Series 200 mounting plates and with all Domi snap-on mounting plates.

Packing

Boxes 150 pcs.

Pallets 3.600 pcs.

Arm 0

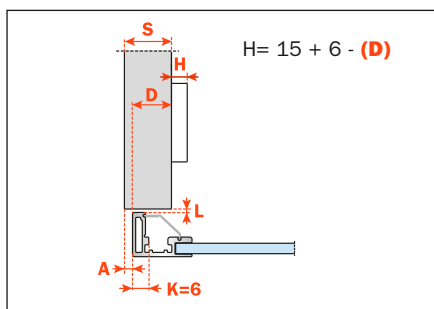

C20PA99

Arm 5

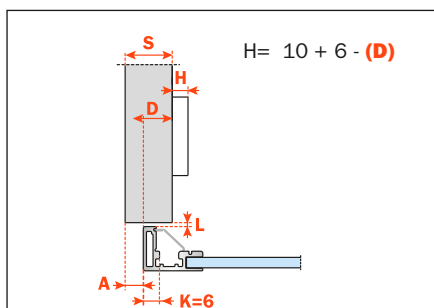

C20PD99

Arm 9

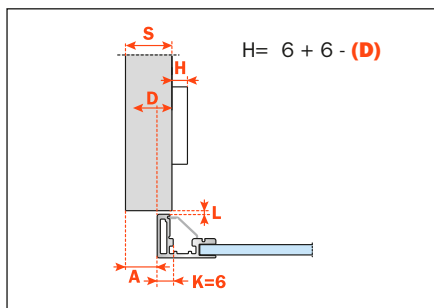

C20PG99

Arm 17

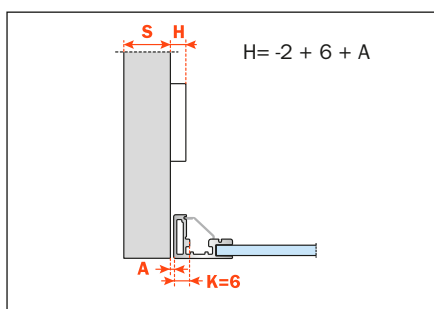

C20PP99



Technical information

Push hinges are equipped with a special spring that acts to open the door independently of the release device.

Hinges for doors with positive angled assembly.

Hinges for the Practical system have been developed for use with special metal profiles. The particular fixing system does not require any profile working. The hinge can be therefore assembled at any point of the frame.

105° opening.

Compatible with all traditional Series 200 mounting plates and with all Domi snap-on mounting plates.

Packing

Boxes 150 pcs.
Pallets 3.600 pcs.

Arm 30°

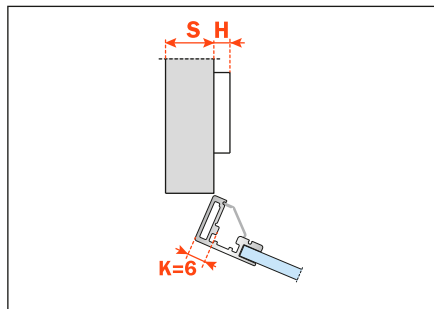

C20PE99

Arm 45°

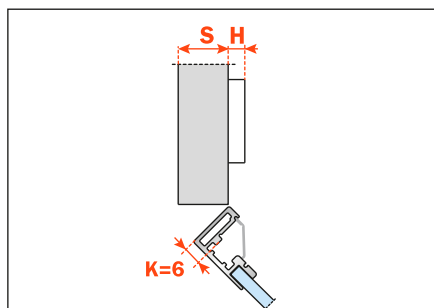

C20PM99

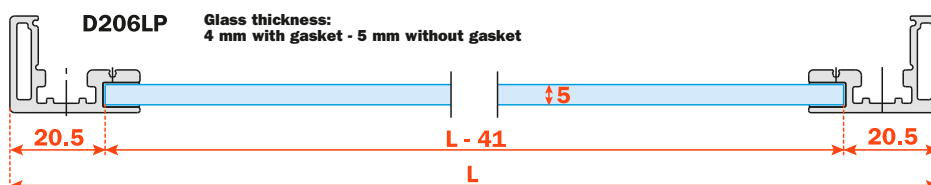
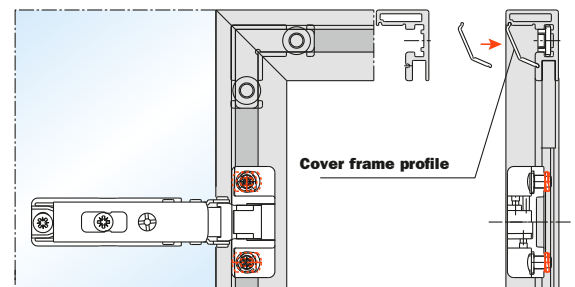
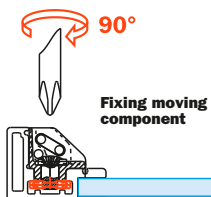
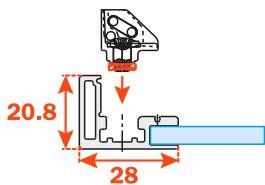

D206LP

Glass thickness:
4 mm with gasket - 5 mm without gasket



Technical information

Push hinges are equipped with a special spring that acts to open the door independently of the release device.

Crampon hinges.

For cabinet sides with 37x32 mm standard drilling.

Hinges for the Practical system have been developed for use with special metal profiles. The particular fixing system does not require any profile working. The hinge can be therefore assembled at any point of the frame.

105° opening.

Compatible with all traditional Series 200 mounting plates and with all Domi snap-on mounting plates.

E min:

61 mm for Series 200 mounting plates.

70 mm for Domi snap-on mounting plates.

74 mm for Domi snap-on mounting plates with back cam.

Packing

Boxes 150 pcs.

Pallets 3.600 pcs.

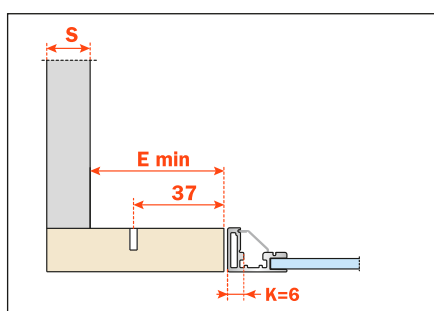

C20PN99AC



Technical information

Push hinges are equipped with a special spring that acts to open the door independently of the release device.

Crampon hinges.

For smaller spaces with 15x32 mm drilling.

Hinges for the Practical system have been developed for use with special metal profiles. The particular fixing system does not require any profile working. The hinge can be therefore assembled at any point of the frame.

105° opening.

Compatible with all traditional Series 200 mounting plates,

28 x 32 mm drilling.

NOT COMPATIBLE with Domi snap-on mounting plates.

Packing

Boxes 150 pcs.

Pallets 3.600 pcs.

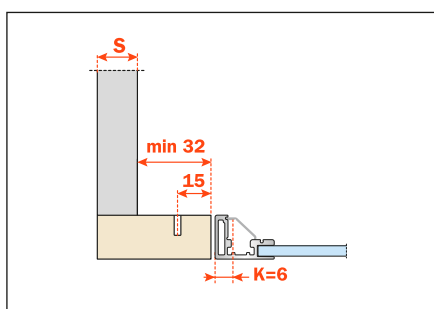

C20PN99

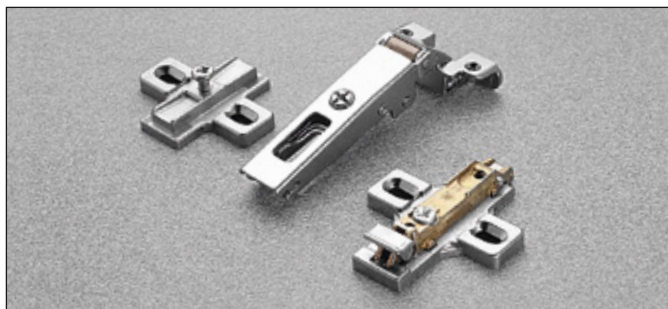

Technical information

Push hinges are equipped with a special spring that acts to open the door independently of the release device.

Hinges specially developed for use with metal profiles.
 105° opening.
 We recommend the use of self-threading screws B 3.5 x 9.5 DIN 7982 to fix C2ZP hinges.
 Compatible with all traditional Series 200 mounting plates and with all Domi snap-on mounting plates.

Packing

Boxes 150 pcs.
 Pallets 3.600 pcs.

Arm 0

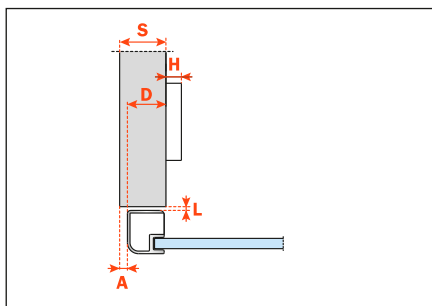

C2ZPA99

Arm 5

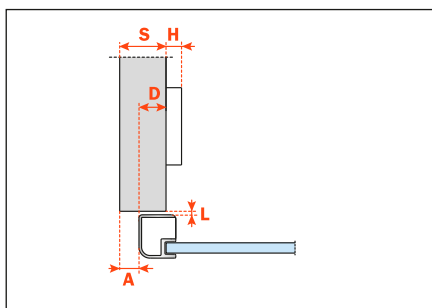

C2ZPD99

Arm 9

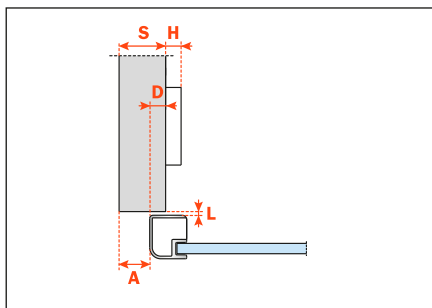

C2ZPG99

Arm 17

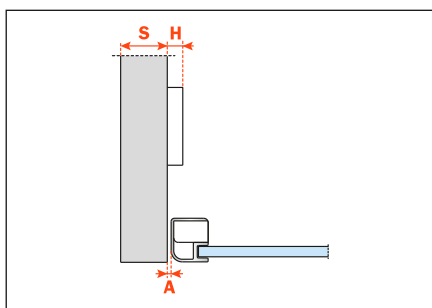

C2ZPP99

Push - Hinges for metal profiles - Complementary hinges

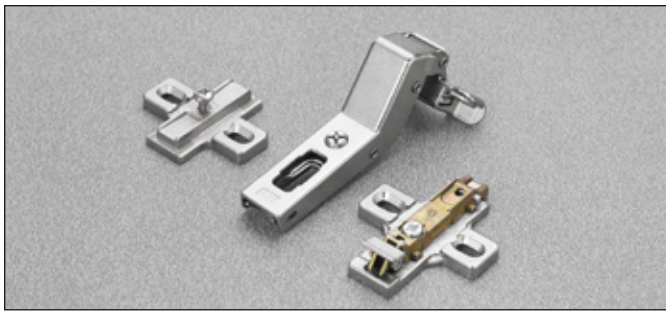

Technical information

Push hinges are equipped with a special spring that acts to open the door independently of the release device.

Hinges for doors with positive angled assembly.

Hinges specially developed for use with metal profiles.
105° opening.

We recommend the use of self-threading screws B 3.5 x 9.5
DIN 7982 to fix C2ZP hinges.

Compatible with all traditional Series 200 mounting plates
and with all Domi snap-on mounting plates.

Packing

Boxes 150 pcs.
Pallets 3.600 pcs.

Arm 30°

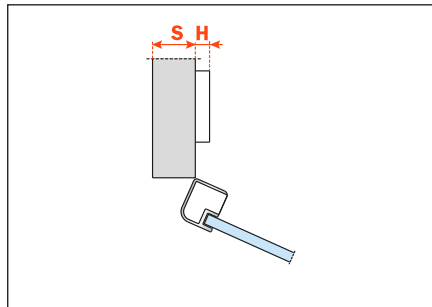

C2ZPE99

Arm 45°

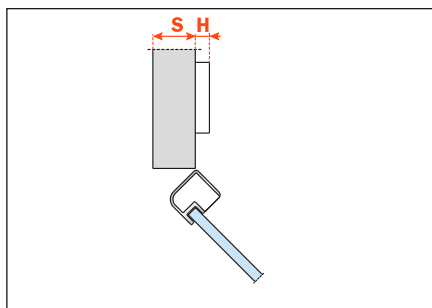

C2ZPM99

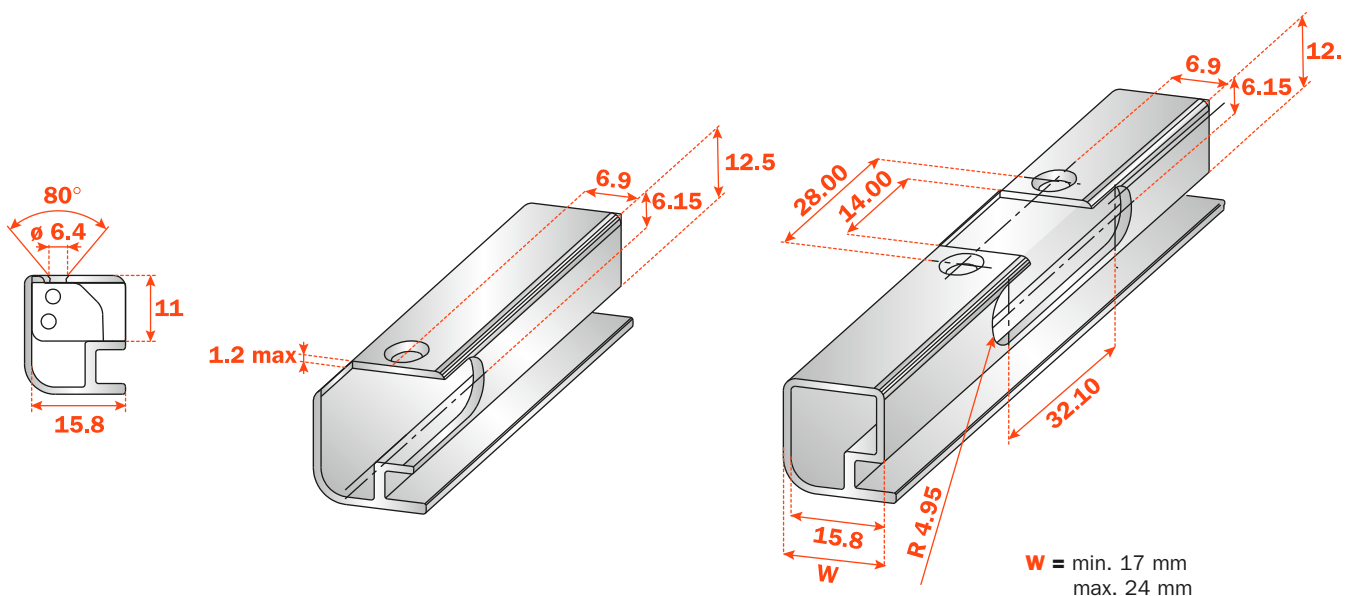

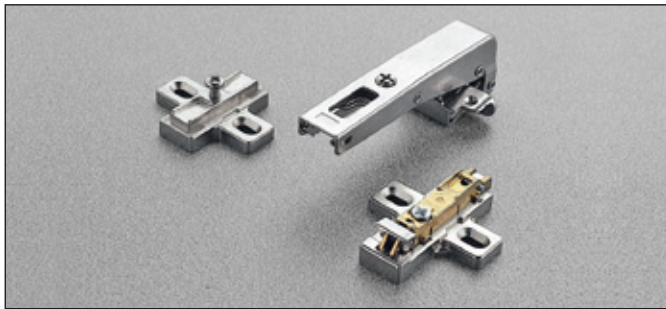

Technical information

Push hinges are equipped with a special spring that acts to open the door independently of the release device.

Crampon hinges.

For cabinet sides with 37x32 mm standard drilling.

Hinges specially developed for use with metal profiles.
105° opening.

We recommend the use of self-threading screws B 3.5 x 9.5 DIN 7982 to fix C2ZP hinges.

Compatible with all traditional Series 200 mounting plates and with all Domi snap-on mounting plates.

Packing

Boxes 150 pcs.
Pallets 3.600 pcs.

E min:

61 mm for Series 200 mounting plates.
70 mm for Domi snap-on mounting plates.
74 mm for Domi snap-on mounting plates with back cam.

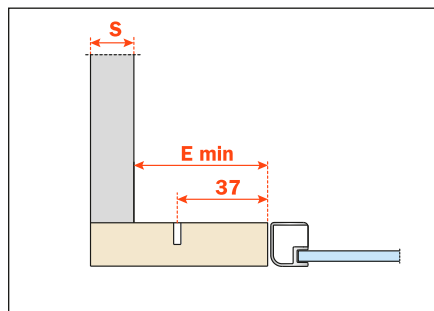

C2ZPN99AC

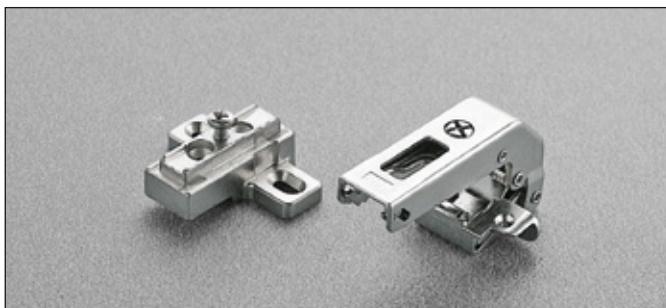

Technical information

Push hinges are equipped with a special spring that acts to open the door independently of the release device.

Crampon hinges.

For smaller spaces with 15x32 mm drilling.

Hinges specially developed for use with metal profiles.
105° opening.

We recommend the use of self-threading screws B 3.5 x 9.5 DIN 7982 to fix C2ZP hinges.

Compatible with all traditional Series 200 mounting plates, drilling 28x32 mm.

NOT COMPATIBLE with Domi snap-on mounting plates.

Packing

Boxes 150 pcs.
Pallets 3.600 pcs.

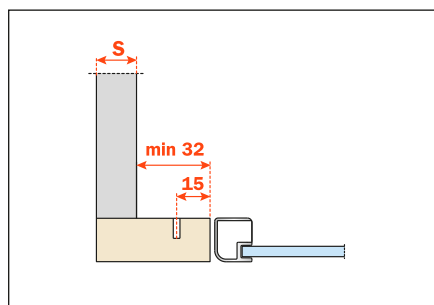

C2ZPN99

Push - Series B hinges



Push - Series B hinges for glass doors

Technical features

No drilling of the glass is required.
Bright nickel plated die-cast cup and arm.

Disclaimer

Salice Series B (CBG) hinges have been developed for use on glass doors and mirrors. Salice will accept no responsibility for any problems associated with the type of adhesive or method of application when used in conjunction with Series B hinges, nor for any consequences of the incorrect mounting of the door. It is recommended that the selected adhesive is subjected to prior testing.

The adhesive may be considered appropriate if the plate, when fixed to the glass, can sustain a minimum torsion load of 160 Nm.

Constant "L" value of 0.7 mm (it does not change during side adjustment).

Approx. number of hinges required according to the door dimension and weight.

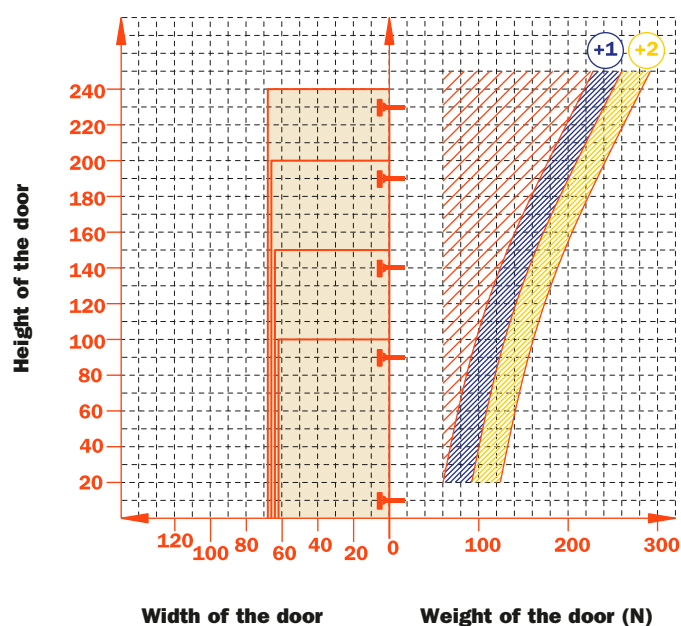

Adjustments

Compensated side adjustment from -1.5 mm to +4.5 mm.
Height adjustment ± 2 mm.
Depth adjustment with Series 200 mounting plates +2.8 mm.
Depth adjustment with Domi snap-on mounting plates from -0.5 mm to +2.8 mm.
Anti-sliding safety stop.

Mounting plates

Symmetrical and asymmetrical bright nickel plated steel or die-cast Series 200 mounting plates.
Snap-on assembly on Domi mounting plates.
Positioning with pre-determined stop on traditional Series 200 mounting plates.

N.B. : Use POZIDRIVE No. 2 screwdrivers for all screws.

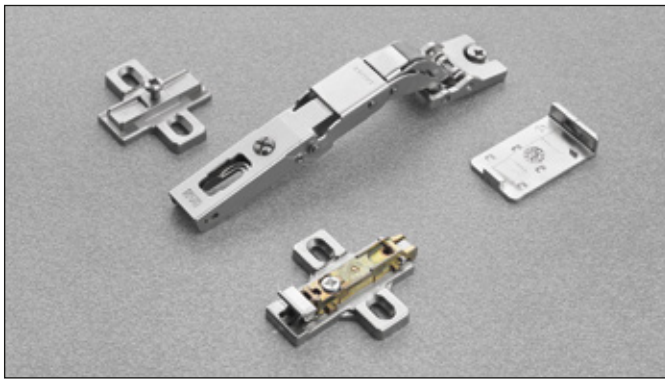

Technical information

Push hinges are equipped with a special spring that acts to open the door independently of the release device.

Hinge for glass doors. No drilling of the glass is required. Possible fixing inset distance on the door (K): from 0 to 22 mm. 110° opening. Compatible with all traditional Series 200 mounting plates and with all Domi snap-on mounting plates.

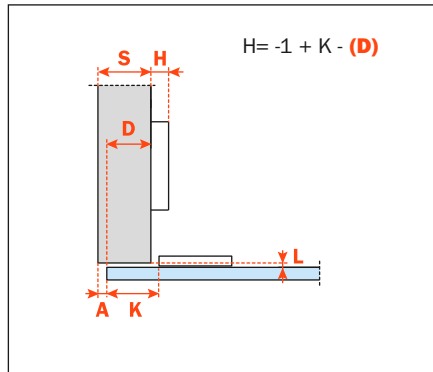
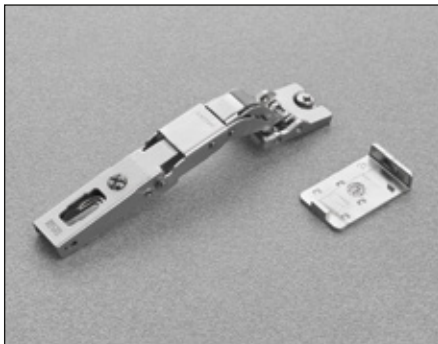

CBGQA99

Packing
Boxes 150 pcs.
Pallets 3.600 pcs.

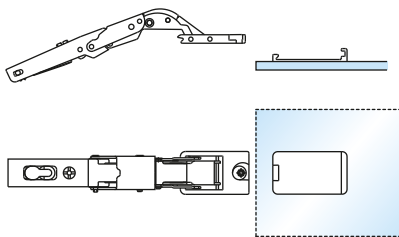

1) The hinge plate must be attached to the glass door or mirror by a special adhesive. We recommend that this operation is carried out by a specialist company. For further information on adhesives and their application, please contact the adhesive manufacturer or your glass supplier.

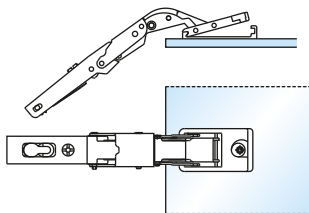

2) Fix the hinge when the plate is bonded to the glass.

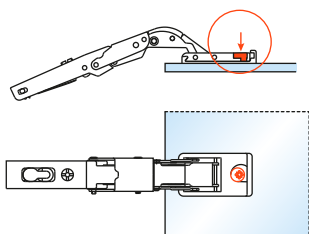

3) Locate the hinge cup onto the plate and rotate the cam.

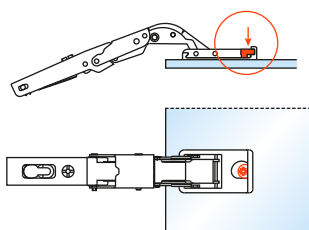

4) The hinge is now fixed to the door.

“C” Value

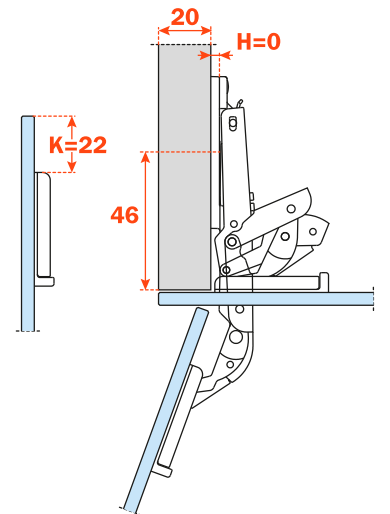

$K = 0 - 22$

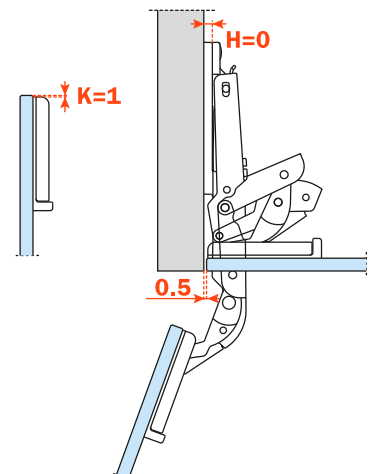

Push - Series B hinges for wooden doors

Technical features

Series B hinges can provide a solution to a number of special applications, which include half-inset doors and doors with moulded profiles.
Dimensions of the 35 mm cup.
Bright nickel plated die-cast cup and arm.

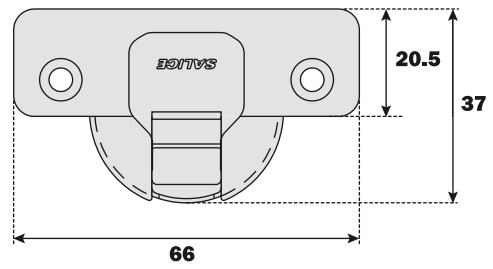

Constant "L" value of 0.7 mm (it does not change during side adjustment).

Approx. number of hinges required according to the door dimension and weight.

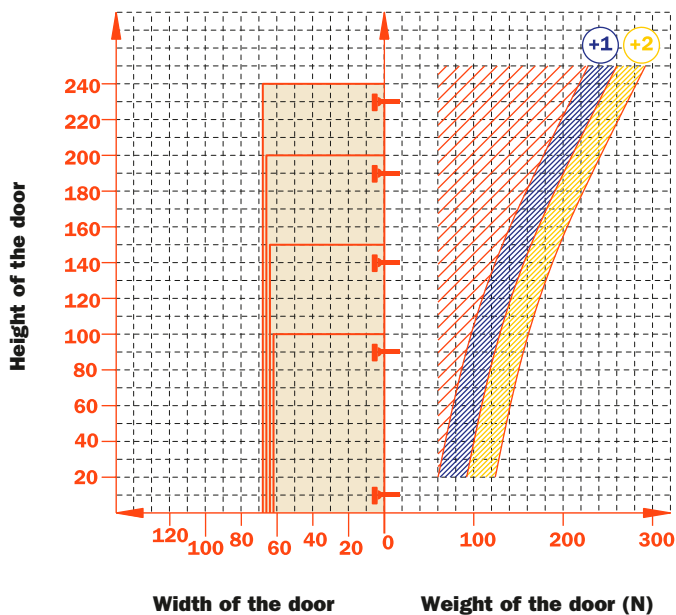

Adjustments

Compensated side adjustment from -1.5 mm to +4.5 mm.
 Height adjustment ± 2 mm.
 Depth adjustment with Series 200 mounting plates +2.8 mm.
 Depth adjustment with Domi snap-on mounting plates from -0.5 mm to +2.8 mm.
 Anti-sliding safety stop.

Mounting plates

Symmetrical and asymmetrical bright nickel plated steel or die-cast Series 200 mounting plates.
 Snap-on assembly on Domi mounting plates.
 Positioning with pre-determined stop on traditional Series 200 mounting plates.

N.B. : Use POZIDRIVE No. 2 screwdrivers for all screws.



	<p>48 35 6 110°</p>	<p>45 35 9.5 110°</p>	<p>52 35 5.5 110°</p>
<p>Wood screw</p>	A	P	U
	<p>48 35 6 10 110°</p>	<p>45 35 9.5 8 110°</p>	<p>52 35 5.5 10 110°</p>
<p>Dowel</p>	B	R	W

Use this table to identify the available drillings and fixings.
 Fill the third position of the hinge code number with the letter or the number corresponding to your choice. I.e.: CB_QA99.

↑
 Fill this position with the chosen letter or number.

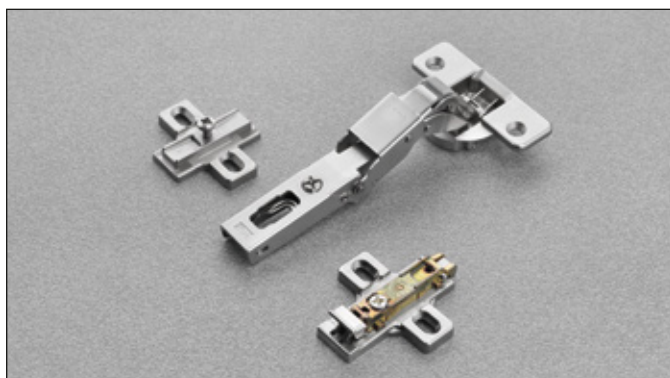

Technical information

Push hinges are equipped with a special spring that acts to open the door independently of the release device and can provide a solution to a number of special applications, which include half-inset doors and doors with moulded profiles.

9 mm deep metal cup.

110° opening.

Possible drilling distance on the door (K): from 3 to 18 mm.

Compatible with all traditional Series 200 mounting plates and with all Domi snap-on mounting plates.

Space needed to open the door

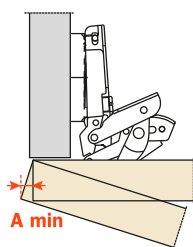

	T=	16	18	20	22	24	26
K=3	A=	0.0	0.0	0.0	0.0	0.3	1.4
K=4	A=	0.0	0.0	0.0	0.0	0.4	1.5
K=5	A=	0.0	0.0	0.0	0.0	0.5	1.9
K=6	A=	0.0	0.0	0.0	0.0	0.7	2.6
K=7	A=	0.0	0.0	0.0	0.0	11.3	12.8
K=8	A=	0.0	0.0	0.0	0.0	10.3	12.9
K=9	A=	0.0	0.0	0.0	0.0	9.3	11.9
K=10	A=	0.0	0.0	0.0	6.0	8.3	10.9
K=11	A=	0.0	0.0	0.0	5.1	7.3	9.9
K=12	A=	0.0	0.0	0.0	4.1	6.3	8.9
K=13	A=	0.0	0.0	1.4	3.3	5.3	7.9
K=14	A=	0.0	0.0	0.7	2.6	4.5	6.9
K=15	A=	0.0	0.0	0.2	2.0	3.8	5.9
K=16	A=	0.0	0.0	0.0	1.4	3.2	5.0
K=17	A=	0.0	0.0	0.0	1.0	2.7	4.4
K=18	A=	0.0	0.0	0.0	0.7	2.2	3.9

The above values are calculated on the assumption that the doors have square edges. They are reduced if the doors have radiussed edges.

Projection of the door

Projection of the door from the cabinet side at the max. opening. The figures are based on a straight arm hinge, H=0 mm thickness of mounting plate and K value = 3 mm.

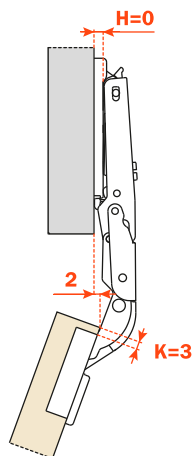

"C" value

With this formula you can obtain the max. thickness of the moulded door that can be opened without touching adjacent carcase sides, doors or walls, whilst bearing in mind the above L-K-T values.

$$C = 5.5 + K + A$$

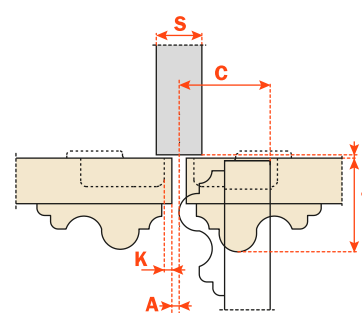
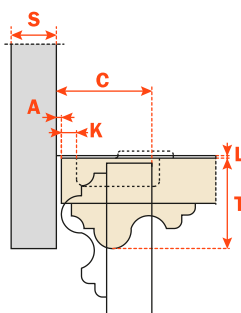

Packing

Boxes 150 pcs.
Pallets 3.600 pcs.

Use these formulas to determine the type of hinge arm, the drilling distance "K" and the height of the mounting plate "H" which is necessary to solve each application problem.

To limit the opening of the hinge, see page 59 chapter "Accessories".

Use the tables "Drillings and fixings" at page 55 to complete the code number of the desired hinge.

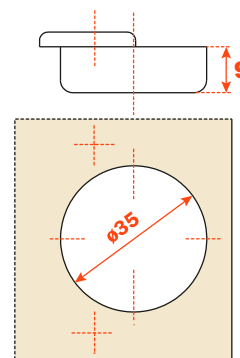

Arm 0

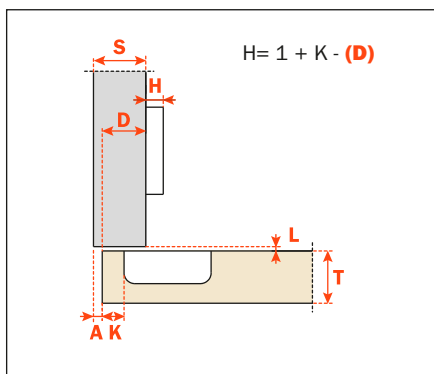
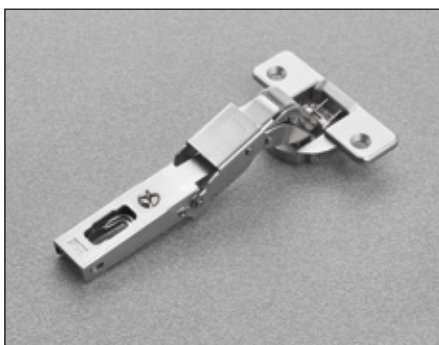

CB_QA99

Accessories



Accessories

Screw cover caps.

S2BX83H9



Symmetrical steel screw cover cap, it can be personalised on request.

For all Series 200 and B hinges.

S2MX83H9



Symmetrical steel screw cover cap with embossed logo.

For all Series 200 and B hinges.

S2XX83A1



Symmetrical plastic screw cover cap, it can be personalised on request.

For all Series 200 hinges.

Flange cover caps

S2XX85H9



Steel flange cover cap, it can be personalised on request.

For all Series 200 hinges.

S2CX85H9



Steel flange cover cap with embossed logo.

For all Series 200 hinges.

Spacers for Series 200 hinges

S2A786XG

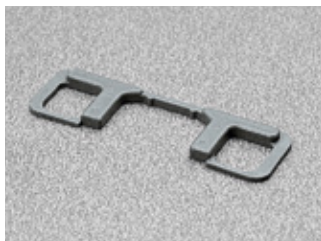

Spacer for hinges with 35 mm diameter.

To be used to reduce the cup drilling depth by 1.4 mm.

Stop devices

S2AF37X3

Stop device

For 155° hinges, it limits opening at 125°.

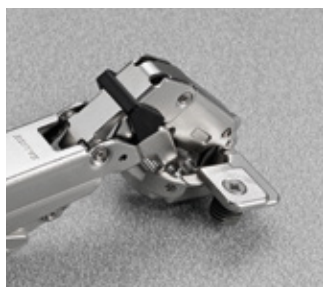

SBA237XG

Stop device

For Series B hinges it limits opening at 90°.

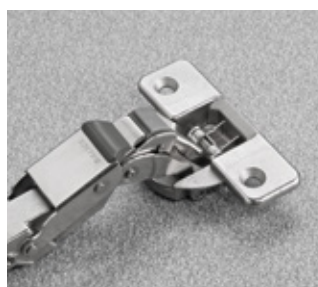
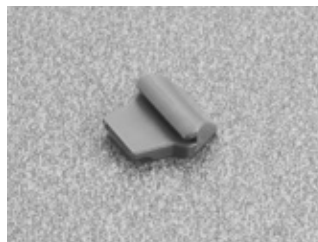

S2BF37XY

Stop device

For 155° hinges, it limits opening at 115°.



S2A637XF

Stop device

For all hinges with 94° opening and 35 mm cup diameter, it limits opening at 86°.



ARTURO SALICE S.p.A.

VIA PROVINCIALE NOVEDRATESE, 10
22060 NOVEDRATE (COMO) ITALIA
TEL. 031 790424
FAX 031 791508
info.salice@salice.com
www.salice.com

DEUTSCHE SALICE GMBH

RUDOLF DIESEL STR. 10
POSTFACH 1154
74382 NECKARWESTHEIM
TEL. 07133 9807-0
FAX. 07133 9807-16
info.salice@deutschesalice.de
www.deutschesalice.de

SALICE UK LTD.

KINGFISHER WAY
HINCHINGBROOKE BUSINESS PARK
HUNTINGDON CAMBS PE 29 6FN
TEL. 01480 413831
FAX. 01480 451489
info.salice@saliceuk.co.uk
www.saliceuk.co.uk

DEUTSCHE SALICE GMBH

VERKAUFSBÜRO NORD
RINGSTRASSE 36/A30 CENTER
32584 LÖHNE
TEL. 05731 15608-0
FAX. 05731 15608-10
vknord@deutschesalice.de
www.deutschesalice.de

SALICE AMERICA INC.

2123 CROWN CENTRE DRIVE
CHARLOTTE NC. 28227
TEL. 704 8417810
FAX. 704 8417808
info.salice@saliceamerica.com
www.saliceamerica.com

SALICE FRANCE S.A.R.L.

ROUTE DE GOA ZAC LES 3 MOULINS
06600 ANTIBES
TEL. 0493 330069
FAX. 0493 330141
info.salice@salicefrance.com
www.salicefrance.com

SALICE CANADA INC.

4025 SLADEVIEW CRESCENT
UNIT # 7-9
MISSISSAUGA, ONTARIO L5L 5Y1
TEL. 905 8208787
FAX. 905 8207226
info.salice@salicecanada.com
www.salicecanada.com

SALICE ESPAÑA, S.L.U.

CALLE COPÉRNICO, 11
POLÍGONO INDUSTRIAL
COLL DE LA MANYA
08403 GRANOLLERS (BARCELONA)
TEL. 938 46 88 61
FAX 938 49 11 97
info.salice@saliceespana.es
www.saliceespana.es