

FR 785 SCC-SC

| | |
|--------------------|--|
| SLIDE TYPE: | Progressive-Action Full-Extension Drawer Slide |
| MOUNTING: | Side Mount |

| | |
|-----------------------|--|
| WIDTH: | 18 mm |
| LOAD CAPACITY: | dynamic up to 60 kg (full-ext.) dynamic up to 48 kg (over-ext.) |



| | |
|---|---|
| ATTACHMENT: | |
| Easy Close Device Packing Unit: 1 set per polybag | ECD 78-S +5°C to +40°C Order No.: ▶ 82503 |
| | ECD 78-C -10°C to +10°C Order No.: ▶ 83442 |
| | ECD 78-F -25°C to -5°C Order No.: ▶ 83443 |

| | |
|------------------|------------------------------|
| MATERIAL: | stainless steel 1.4509 (SCC) |
|------------------|------------------------------|

| | |
|------------------|-----------------------|
| FEATURES: | solid delrin* rollers |
|------------------|-----------------------|

SPECIFICATIONS & NOTES:

- ▶ cabinet profile with bayonet mounting tabs
- ▶ drawer profile without screw holes
- ▶ high lateral stability through specially formed middle profile (material thickness 2 mm) and guide rollers
- ▶ ideal running characteristic and smoothness of running through integrated progressive-action
- ▶ safety clip mounted in middle profile
- ▶ double-sided captive profile
- ▶ self closing, soft stop

① compatible with regular-extension drawer slides FR 1052 CS-SC

① tool-less quick assembly of the cabinet profile

① standard grid rail (see drawing)

⊕ also available with **Easy Close Device (ECD)**

① on request, also available as heat resistant model (up to 110° C) – load capacity 45 kg (full-ext.), 35 kg (over-ext.)

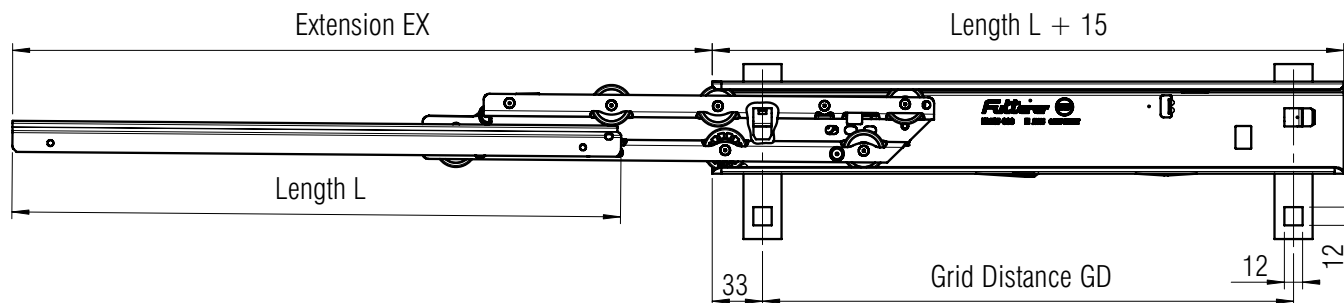
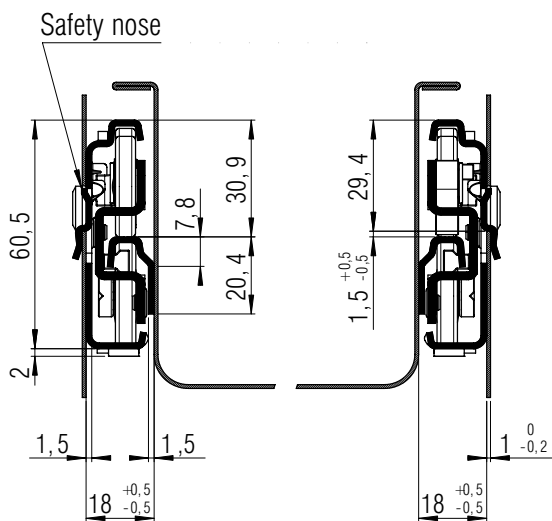

| L mm | EX full-ext. | EX over-ext. | GD mm | Weight per pair (kg) | Order No. full-ext. | Order No. over-ext. |
|---------|-----------------|-----------------|----------|-------------------------|------------------------|------------------------|
| 335 | 320 | 395 | 299 | * | * | * |
| 350 | 335 | 410 | 299 | * | * | * |
| 385 | 370 | 445 | 349 | * | * | * |
| 400 | 385 | 460 | 349 | 1,74 | ▶ 8324 | * |
| 435 | 420 | 495 | 399 | * | * | * |
| 450 | 435 | 510 | 399 | 1,98 | ▶ 8326 | * |
| 485 | 470 | 545 | 449 | * | * | * |
| 500 | 485 | 560 | 449 | 2,22 | ▶ 8328 | * |
| 535 | 520 | 595 | 499 | * | * | * |
| 550 | 535 | 610 | 499 | 2,46 | ▶ 8330 | * |
| 585 | 570 | 645 | 549 | * | * | * |
| 600 | 585 | 660 | 549 | 2,70 | ▶ 8332 | * |
| 635 | 620 | 695 | 599 | * | * | * |
| 650 | 635 | 710 | 599 | 2,94 | ▶ 8334 | * |
| 685 | 670 | 745 | 649 | * | * | * |
| 700 | 685 | 760 | 649 | * | * | * |
| 735 | 720 | 795 | 699 | * | * | * |
| 750 | 735 | 810 | 699 | * | * | * |

Packing Unit: **5 sets per box**

▶ prompt delivery * on request