

FR 505 SCC

SLIDE TYPE:	Regular-Extension Drawer Slide
MOUNTING:	Bottom Mount

WIDTH:	15 mm
LOAD CAPACITY:	dynamic up to 100 kg



MATERIAL: stainless steel 1.4509 (SCC)

FEATURES: chrome steel ball bearings with integrated nylon gliding ring

SPECIFICATIONS & NOTES:

- ▶ cabinet and drawer profile with screw holes
- ▶ lateral stability provided by specially shaped profiles
- ▶ self-closing
- ▶ rear backstop

ⓘ on request, also available in a heat resistant version for -40 to +210 °C.

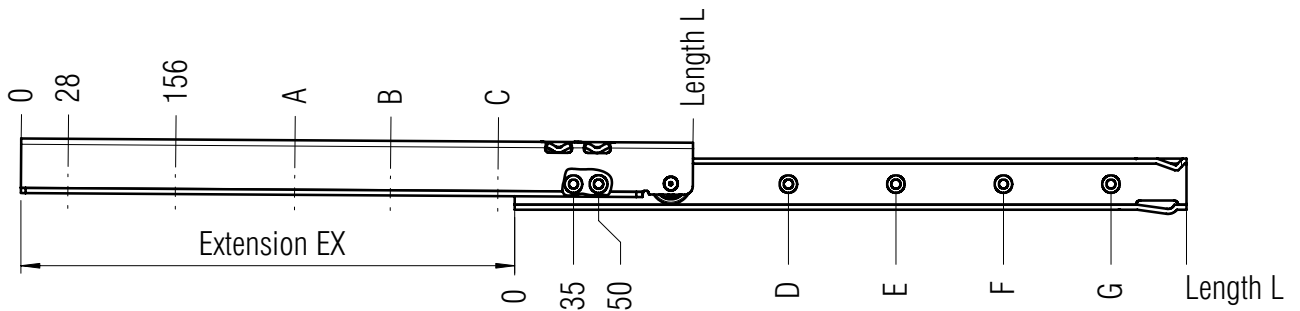
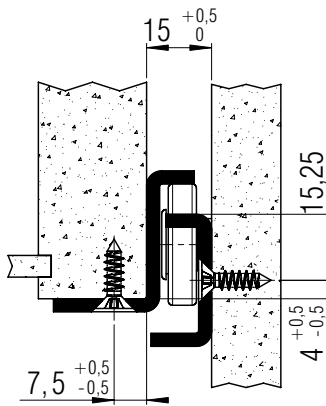
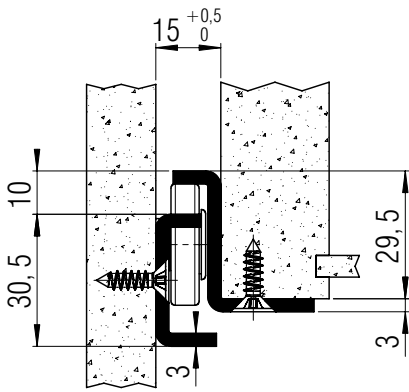

screw holes for 4,5 mm spax screws

L mm	EX mm	A mm	B mm	C mm	D mm	E mm	F mm	G mm	Weight per pair (kg)	Order No.
400	294	348			163	355			2,08	▶ 1060
450	344	348			163	355			2,33	▶ 1061
500	394	348	444		163	355	451		2,57	▶ 1062
550	444	348	476		163	355	483		2,82	▶ 1063
600	494	348	540		195	355	547		3,06	▶ 1064
650	544	348	540		163	355	547		3,31	▶ 1065
700	584	380	540	636	163	355	547	643	3,55	▶ 1066
750	634	380	540	636	163	355	547	643	3,80	▶ 1067

Packing Unit: 5 sets per box

▶ prompt delivery