

FR 1051 SCC

SLIDE TYPE:	Regular-Extension Drawer Slide
MOUNTING:	Side Mount

WIDTH:	15 mm
LOAD CAPACITY:	dynamic up to 40 kg

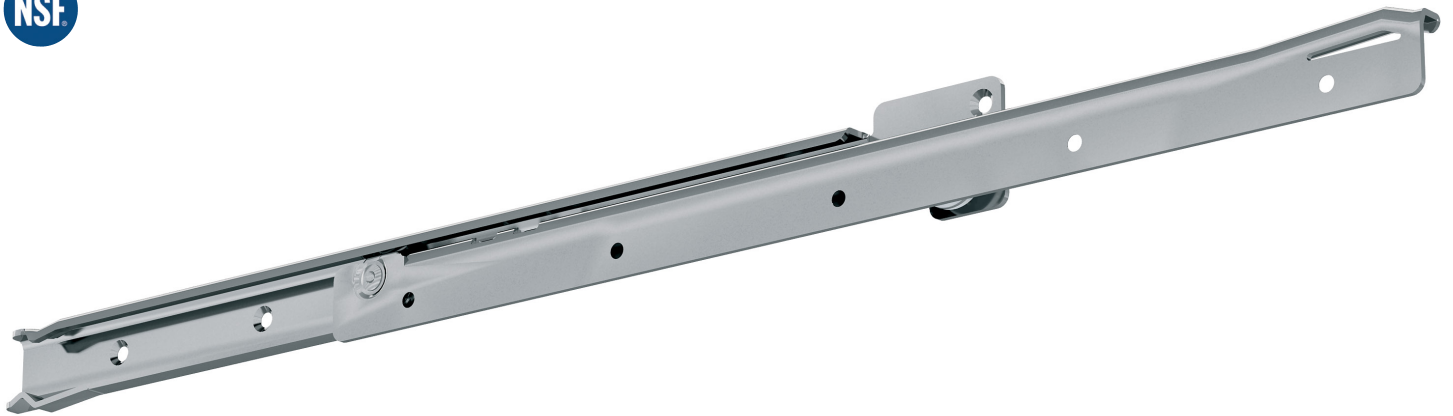

MATERIAL: stainless steel 1.4509 (SCC)

FEATURES: delrin*-encased chrome steel ball bearings

- SPECIFICATIONS:**
- ▶ cabinet and drawer profile with screw holes
 - ▶ lateral stability provided by specially shaped profiles
 - ▶ single-sided captive profile (right)
 - ▶ rear backstop
 - ▶ self closing
-
- ① compatible with full-extension drawer slide FR 6010 SCC
 - ① on request, also available in a heat-resistant version for -40 to +210 °C

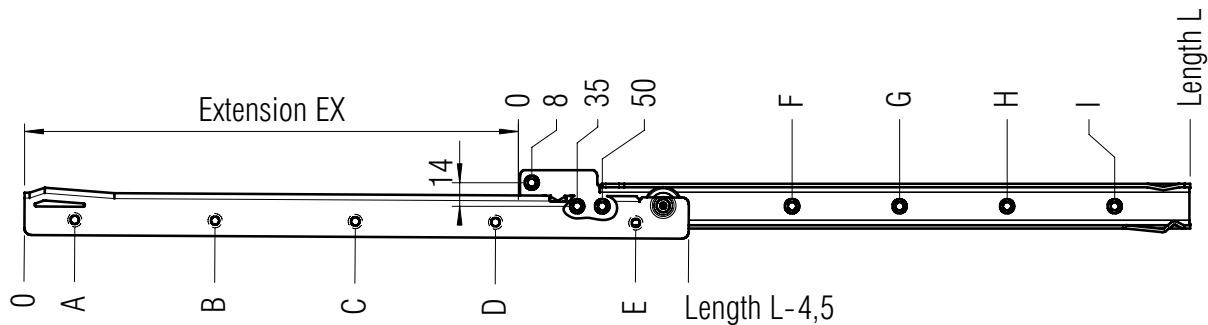
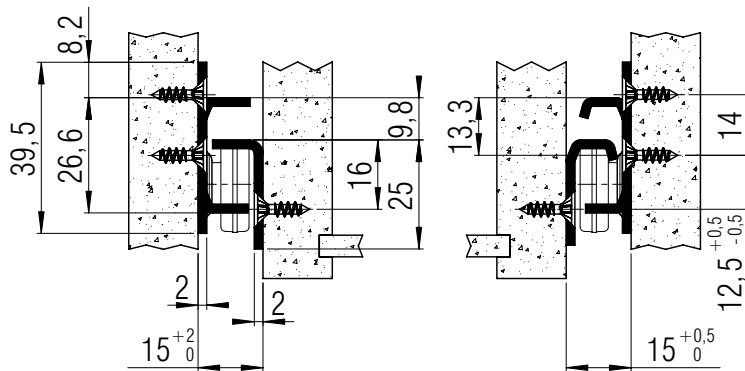

screw holes for 3,5 mm spax screws

L mm	EX mm	A mm	B mm	C mm	D mm	E mm	F mm	G mm	H mm	I mm	Weight per pair (kg)	Order No.
400	294	28	156	348			163	355			1,00	▶ 1078
450	344	28	156	348			163	355			1,12	▶ 1079
500	394	28	156	348	444		163	355	451		1,24	▶ 1080
550	424	28	156	348	476		163	355	483		1,36	▶ 1081
600	474	28	156	348	540		195	355	547		1,48	▶ 1082
650	524	28	156	348	540		163	355	547		1,60	▶ 1083
700	574	28	156	380	540	664	163	355	547	643	*	*
750	624	28	156	348	572	714	163	355	547	643	*	*

Packing Unit: 10 sets per box

▶ prompt delivery * on request