

**KRABY** is the new gas and oil stay conception with a completely new design to open flap doors. It has been conceived to be installed by using standard automatic drilling processes. It is available in several newton strengths to suit small - medium - big - maxi size doors. It can be fixed directly on solid doors or wider aluminium frame section doors. For small aluminium sections a range of special adaptors is available.

**KRABY 244mm** variant is available in:

- **Automatic S.F. version**, once you begin to open the door, it continues to open gently and completely by itself.
- **Friction version**, the stay holds the door in any position required.

**Useful method:**

- For aligning nearby doors through the rotary knob placed on the piston base plate.
  - To change the time in opening and closing of the door by adjusting the position of the piston base plate within the "U" slot of the side bracket.
- All the parts (stay excluded) are in zinc alloy nickel plated and engineering plastic.

In accordance with Italian regulation UNI 8607

**PATENTED**



## DRILLING PLAN

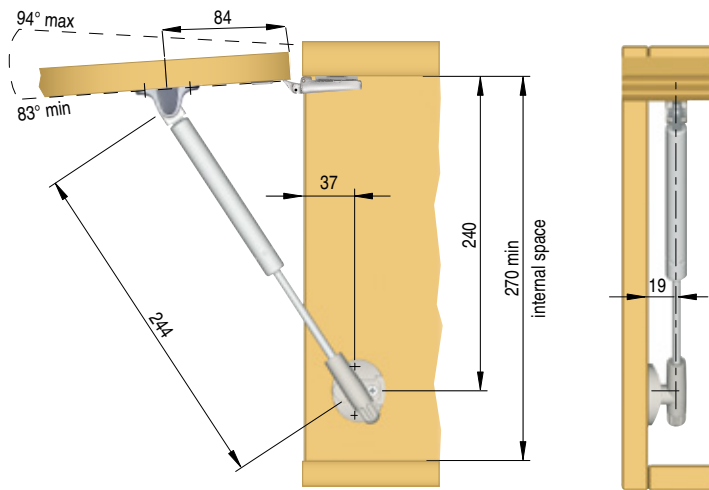

The dimensions of the above drilling plan refer to carcasses which use standard sprung hinges and mounting plates 0mm.

## DETAILS

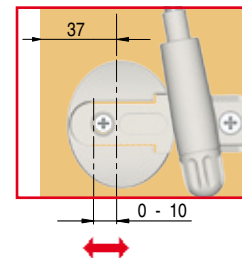
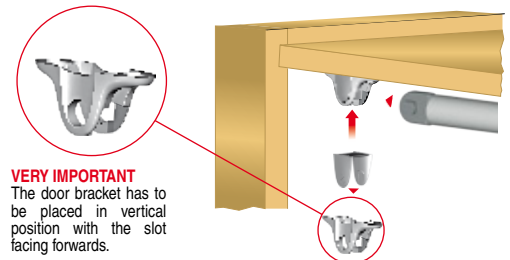

## TECHNICAL DRAWING AND CHART TO FIND THE RIGHT STRENGHT

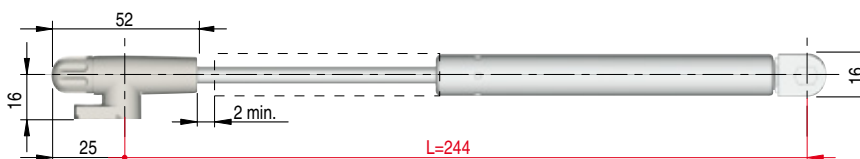

These charts refer to chipboard or MDF 18mm doors and aluminium frame doors with glass 4mm thick. These are experimental results to be checked by the customer. Our technical department is at your disposal to test further cases out of this chart.

### FRICITION OPENING VERSION

Width door (mm)	450		600		900		1200		1500	
Height door (mm)	Kg	Stays x N	Kg	Stays x N	Kg	Stays x N	Kg	Stays x N	Kg	Stays x N
300 - 350	1,6 - 1,8	1 x 45	2,1 - 2,5	1 x 60	3,2 - 3,7	1 x 90	4,2 - 4,9	2 x 45	5,3 - 6,1	2 x 60
351 - 400	1,8 - 2,1	1 x 45	2,5 - 2,8	1 x 60	3,7 - 4,2	2 x 45	4,9 - 5,6	2 x 60	6,1 - 7,0	2 x 90
401 - 450	2,1 - 2,4	1 x 60	2,8 - 3,2	2 x 45	4,2 - 4,7	2 x 60	5,6 - 6,3	2 x 90	7,0 - 7,9	2 x 90
451 - 500	2,4 - 2,6	2 x 45	3,2 - 3,5	2 x 60	4,7 - 5,3	2 x 60	6,3 - 7,0	2 x 120	-	-
501 - 550	2,6 - 2,9	2 x 45	3,5 - 3,9	2 x 60	5,3 - 5,8	2 x 90	7,0 - 7,7	2 x 120	-	-

Strenght (N)	45	60
Part. no	42011010NN	42012010NN

Strenght (N)	90	120
Part. no	42013010NN	42014010NN

### AUTOMATIC OPENING VERSION

Width door (mm)	450		600		900		1200	
Height door (mm)	Kg	Stays x N	Kg	Stays x N	Kg	Stays x N	Kg	Stays x N
300 - 350	1,6 - 1,8	1 x 80	2,1 - 2,5	1 x 80	3,2 - 3,7	2 x 80	4,2 - 4,9	2 x 80
351 - 400	1,8 - 2,1	1 x 80	2,5 - 2,8	2 x 50	3,7 - 4,2	2 x 80	4,9 - 5,6	2 x 100
401 - 450	2,1 - 2,4	2 x 50	2,8 - 3,2	2 x 80	4,2 - 4,7	2 x 100	-	-
451 - 500	2,4 - 2,6	2 x 80	3,2 - 3,5	2 x 80	4,7 - 5,3	2 x 120	-	-
501 - 550	2,6 - 2,9	2 x 80	3,5 - 3,9	2 x 100	-	-	-	-
551 - 600	2,9 - 3,2	2 x 100	3,9 - 4,2	2 x 120	-	-	-	-

Strenght (N)	50	80
Part. no	42110010NN	42111010NN

Strenght (N)	100	120
Part. no	42112010NN	42113010NN