

FR 9000

SLIDE TYPE:	Regular-Extension Aluminium Drawer Slide
MOUNTING:	Bottom and Side Mount

WIDTH:	56 mm
LOAD CAPACITY:	dynamic up to 200 kg



MATERIAL:	Aluminium
------------------	-----------

FEATURES:	nylon rollers and nylon-encased ball bearings
------------------	---

SPECIFICATIONS & NOTES:

- ▶ modular sliding system comprised of aluminum components for a wide variety of applications
 - ▶ 200 kg weight capacity, regular extension is approximately 70 % of profile's length
 - ▶ the special interior shape of the profile compensates for installation inaccuracies in width, height and angular direction
 - ▶ a recess for a M6 (DIN984) Allan head bolt with a centerline groove to accurately mark the position of the holes
 - ▶ simple and secure fastening
- ① the system FR9000 can be obtained completely assembled or all parts separately to be fabricated by the user enabling to produce odd sizes with the individual components

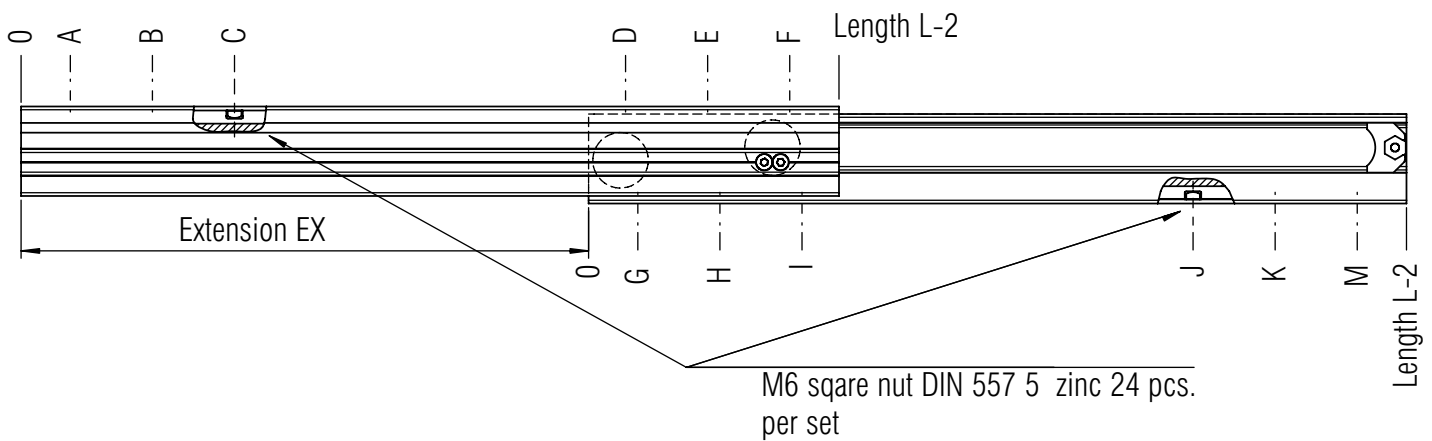
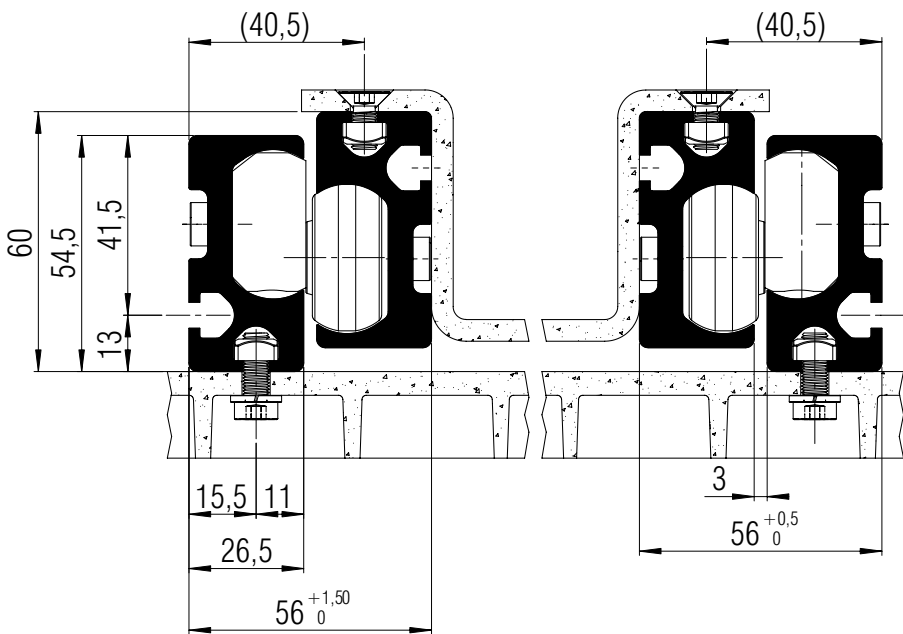

L mm	450	500	550	600	650	700	750	800	850	900	950	1000	1100	1200	1300	1400	1500	1600	1700	1800	1900	2000	2100	2200	2300	2400	2500
EX	315	350	385	420	455	490	525	560	595	630	665	700	770	840	910	980	1050	1120	1190	1260	1330	1400	1470	1540	1610	1680	1750

FR 9000

SLIDE TYPE:	Regular-Extension Aluminium Drawer Slide
MOUNTING:	Bottom and Side Mount

WIDTH:	56 mm
LOAD CAPACITY:	dynamic up to 200 kg

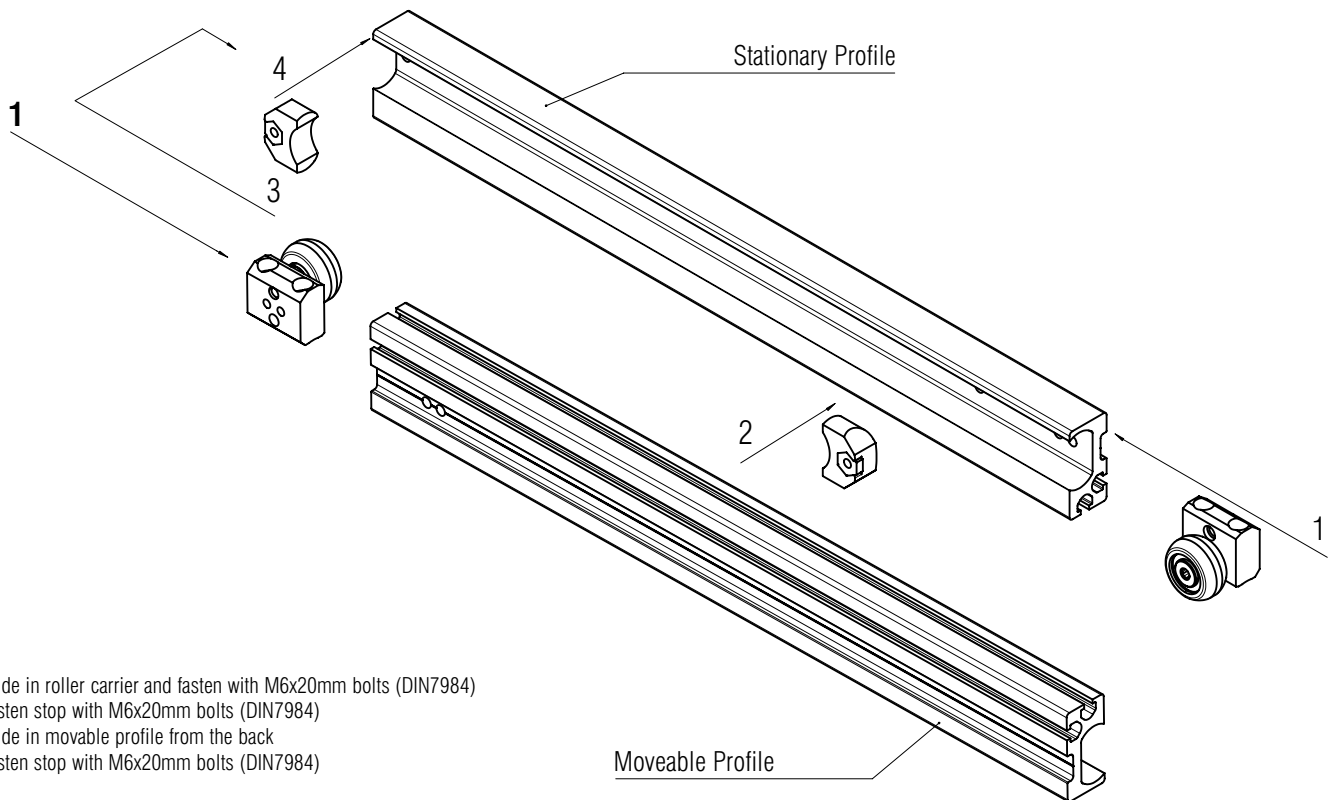

- 1.) slide in roller carrier and fasten with M6x20mm bolts (DIN7984)
- 2.) fasten stop with M6x20mm bolts (DIN7984)
- 3.) slide in movable profile from the back
- 4.) fasten stop with M6x20mm bolts (DIN7984)

EXAMPLE FR9000 REGULAR EXTENSION:

- ▶ 2 outer profiles with 4 stops and 2 roller carriers
- ▶ 2 inner profiles with 2 roller carriers
- ▶ all profiles have the same length, extension to one side

EXAMPLE FR9000 REGULAR EXTENSION:

- ▶ 2 outer profiles with 4 stops
- ▶ 2 inner profiles with 4 roller carriers
- ▶ different lengths of profiles, extension to both sides

EXAMPLE FR9000 TABLE EXTENSION:

- ▶ 2 outer profiles with 6 stops
- ▶ table top with roller carriers arranged in pairs

Individual components for Fabricators:		Order No.
Extruded Profile	Length 6140 mm	▶ 9201
rollers and stops/Regular Extension	2 pcs. solid rollers (tolerance compensating), 2 pcs. ballbearing rollers, 4 pcs. stops, 16 pcs. M6x20mm bolts (DIN7984), 24 pcs. M6 square nuts (DIN557), Packing: 1 box	▶ 9200
Minimum order quantity, pricing and lead time on request		▶ prompt delivery

Assembled Regular Extension Slide:	Length mm	EX mm	Weight	Order No.
FR 9000. 1600 mm	1600	1120	*	*
FR 9000. 1900 mm	1900	1330	*	*
FR 9000. 2300 mm	2300	1610	*	*
Minimum order quantity, pricing and lead time on request				* on request