

FR 6000

SLIDE TYPE:	Full-Extension Drawer Slide - Progressive-Action
MOUNTING:	Side Mount

WIDTH:	15 mm
LOAD CAPACITY:	dynamic up to 50 kg



MATERIAL:	steel or white powder coated
------------------	------------------------------

FEATURES:	delrin* encased steel ball bearings
------------------	-------------------------------------

SPECIFICATIONS:
<ul style="list-style-type: none"> ▶ excellent lateral stability provided by specially shaped profiles ▶ with over-extension of at least 30 mm (standard) ▶ holdout catch on middle profile for easy drawer insertion ▶ double holes at front of cabinet profile reinforce against heaviest loads ▶ double-sided captive profile ▶ soft stop

*DuPont (TM) Delrin®

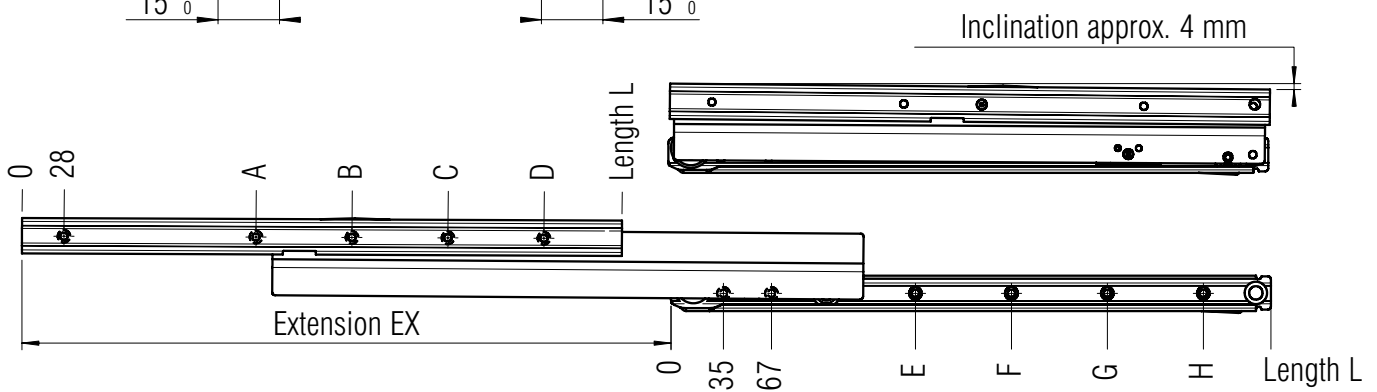
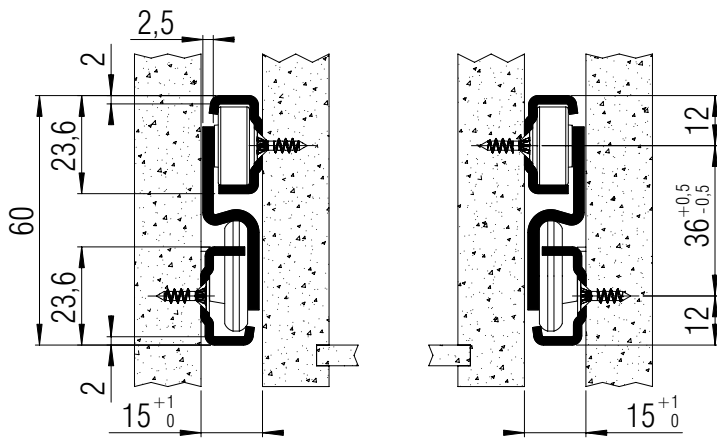

screw holes for 3,5 mm spax screws

L mm	EX mm	A mm	B mm	C mm	D mm	E mm	F mm	G mm	H mm	Weight per pair (kg)	Order No. white
300	300	124	252			131	259			1,49	▶ 3149
350	380	156	284			163	291			1,73	▶ 3150
400	430	156	316			163	323			1,96	▶ 3151
450	480	188	380			195	387			2,20	▶ 3152
500	530	156	284	412		163	291	419		2,43	▶ 3153
550	580	156	316	476		163	323	483		2,67	▶ 3154
600	630	188	348	540		195	355	515		2,89	▶ 3155
650	680	188	380	572		195	387	579		3,17	*
700	730	124	252	476	636	163	323	483	643	3,40	*
750	780	156	284	508	700	195	355	515	675	3,64	*
800	830	188	316	540	732	195	355	547	739	3,87	*

Packing Unit: 6 sets per box

▶ prompt delivery * minimum order quantity and lead time on request